



PRODUCT & SERVICES GUIDE

**WE HELP
CUSTOMERS
DELIVER THEIR
PROJECTS MORE
QUICKLY, SAFELY
AND EFFICIENTLY**

mabey





WHO WE ARE



OUR VISION is that – we are recognised as the leading engineering and construction services provider in our chosen markets.

OUR PURPOSE – why we exist – is to help customers deliver their projects more quickly, safely and efficiently. We achieve this by providing our value-adding engineering expertise, services and products in the right way to our customers.

WHAT WE DO



Here in Australia we are a temporary bridging and ground works equipment hire business with a core focus on the supply of safe trench shoring systems (aluminium & steel), hydraulic shoring (bracing), temporary ground protection (road/bog mats) and modular panel bridging. We actively supply our products and services to Australia's civil construction, resources and commercial construction sectors.

We don't just supply equipment for hire though, we work closely with our clients to ensure the safest and most efficient systems are used on site. We provide engineering support, temporary works designs and account management services with an objective to build strong relationships with our clients and to provide innovative solutions to common groundworks problems.



OUR COMMITMENT TO SAFETY

Workplace Health and Safety is the very heart of our business and always will be. As an Australian and New Zealand safety leader in the provision of shoring groundworks products, our operations comply and exceed Australian and New Zealand Standards AS:4744.1 and AS:5047. Product specification and installation guides are available for every hire across our entire product range with clear, easy to follow instructions. We provide data sheets, technical reference, user and installation guides all of which allow our equipment to be deployed safely and effectively and for comprehensive risk assessments to be completed.

We operate to ensure everyone gets home, injury free, every day.

CONTENTS



TRENCH SHORING	04
ULTRA SHIELDS	06
VERSA SHIELDS	08
HEAVY DUTY SHIELDS	10
MODULAR SHORING	12
HYDRAULIC BRACING	13
SHORING ACCESSORIES	14
TEMPORARY GROUND PROTECTION	18
HYDRAULIC BRACING	22
TRENCH SHEETS SHEET PILING & EMV	24
STEEL ROAD PLATES	26
TEMPORARY BRIDGING	27
VALUE ADDED SERVICES	30
CONVERSIONS TABLE	33

FULL RANGE TRENCH SHORING

As trench shoring pioneers and specialists in the Australian groundworks market we have a shield system to suit any trench shoring application. We pioneered Mabey Ultra Shields, the next generation ultra-strong, ultra-lightweight aluminium shoring that does not compromise on strength. Shoring in the Mabey Ultra Shield range includes some of the lightest boxes available in the market today, which in turn delivers safety and operational benefits to your sites.

Adding to our range of aluminium shoring is the new generation Versa Shields. Australia's first drag capable trench shield. Versa Shields are designed to take more of the knocks while

maintaining the strength of Mabey Ultra Shields. The 7m Versa Shield is also designed to deliver the largest internal working widths at 6m. Another first for Australia and New Zealand.

If it is a harder working trench shield you require for the toughest of ground conditions, then choose from our Mabey Heavy Duty steel shoring range. When shield weights and lifting capacity aren't as big of a concern as the ground pressure acting on your trench excavation then our Heavy Duty boxes are what you need. Rated up to 100kPa or more, many of our Heavy Duty Shields are stronger and lighter than competitors' steel boxes.



Versa Shield



Heavy Duty Shield

SELECTION GUIDE

Panel Type	Ultra Shields	Versa Shields	Heavy Duty Shields
Aluminium	● ● ●	● ● ●	No
Steel	No	No	● ● ●
Lightweight (<2.5t)*	● ● ●	● ●	No
<25t Excavator*	● ● ●	● ●	Not Recommended
>25t Excavator*	Not Required	●	● ● ●
<50kPa	● ● ●	● ● ●	● ● ●
>50kPa	●	● ●	● ● ●
Drag-capable	Not Recommended	● ●	● ●
Restrictive, built up sites	● ● ●	● ● ●	●
Working internals >4m	No	●	● ●
Type C-80 > 4m depths	● ●	● ●	● ● ●

Guide

- Applies to some shields in the range
- ● ● Applies to all shields in the range

- ● Applies to most shields in the range



Ultra Shield



Versa Shield

ULTRA SHIELDS

ultra-lightweight, ultra-strong aluminium shoring

The original, high performing aluminium shoring range available in Australia. These shields have revolutionised trench shoring since their introduction. The ultra-lightweight, ultra-strong design has resulted in significant project time and cost savings for many contractors without compromising the shield's rated capacity.

The Ultra Shield's lightweight properties have also improved safety on site with increased manoeuvrability and reduced lift capacities – especially in built-up working areas with tighter or restricted working environments. In many cases the Mabe Ultra Shields are often as strong, but up to half the weight of traditional competitor's steel boxes.

FEATURES & BENEFITS

- Ultra lightweight for smaller plant and machinery use, save on plant hire costs
- Simple strut and pin assembly for quick install and increased productivity
- Available in panel lengths up to 7.2m
- Manhole shields available in this range
- Larger shield sizes handle longer trenches with fewer shield repositions when laying pipe
- Strong design built to withstand up to 70kPa
- Working internal widths up to 4m
- Up to 2.4m under strut clearance with high clear configuration
- No fabric lifting slings required

“Our range of Ultra Shield aluminium shoring is your answer to significant savings on site”.



SPECIFICATIONS

Panel Type	Panel Length (mm)	Panel Height (mm)	Panel Width (mm)	Clear Working Dimensions				Safe Working Load (kPa)	Weight (incl 1m strut) (kg)
				Clearance Length (mm) strut - strut	Min Width (mm)	Max Width (mm)	Understrut Clearance (mm)		
Standard Base	2,400	1,200	56	2,100	600	1,800	300	20-50*	130
Manhole Base	2,000	2,000	56	1,850	2,000	4,000	560	30	376
Manhole Base	2,400	2,400	90	2,200	2,000	4,000	1,150	50	900
Lower	1,800	2,000	90	1,480	600	4,000	900	50	300
Extension	1,800	1,600	90	1,480	600	4,000	350	50	240
Lower	3,100	2,000	90	2,780	600	4,000	900	50	620
Extension	3,100	2,000	90	2,780	600	4,000	550	50	620
Lower	3,600	2,400	90	3,280	600	4,000	1,350	36	900
Extension	3,600	2,000	90	3,280	600	4,000	950	36	750
Lower	4,000	2,400	150	3,680	600	4,000	1,350	70	1,200
Extension	4,000	2,000	150	3,680	600	4,000	950	70	960
Lower	6,000	2,400	150	5,700	600	4,000	1,350	45	1,800
Extension	6,000	2,400	150	5,700	600	4,000	1,100	45	1,800
Lower	7,200	2,400	150	6,880	600	4,000	1,350	36	2,100
Extension	7,200	2,400	150	6,880	600	4,000	1,100	36	2,100

* Depending on the number and placement of struts used



VERSA SHIELDS

versatile aluminium shoring

Australia's first drag capable range of aluminium trench shields. Mabey's Versa Shield range offers the benefits of an aluminium shoring shield with structural and design modifications that enables aluminium shields to do more than ever before! If you need a lighter-weight shoring solution that can stand up to the knocks and can provide greater working internal widths as well as better under strut clearances, a shield from the Mabey Versa range is your answer.

“When you need an aluminium shoring solution that can take the knocks”.

FEATURES & BENEFITS

- Lightweight for smaller plant and machinery use
- Simple strut and pin assembly for quick install and increased productivity
- Available in panel lengths up to 7.2m
- Strong design built to withstand up to 100kPa
- Working internal widths up to 6m
- Reinforced panel top section for greater durability
- Reinforced collar and strut configuration for dragging shields in trench
- Heavy duty stacking bracket and connectors
- Up to 2.4m under strut clearance with high clear configuration

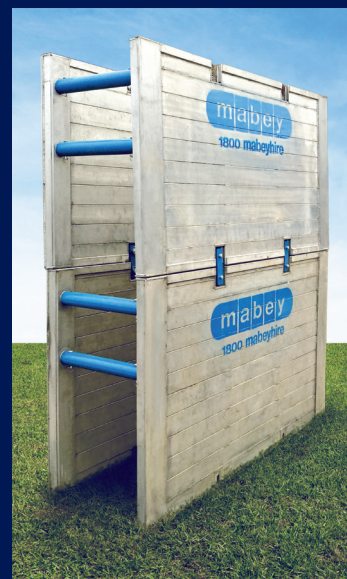

SPECIFICATIONS

Panel Type	Panel Length (mm)	Panel Height (mm)	Panel Width (mm)	Clearance Length (mm) strut - strut	Min Width (mm)	Max Width (mm)	Understrut Clearance (mm)	Safe Working Load (kPa)	Weight (incl 1m strut) (kg)
Lower	2000	2000	84	1600	600	4000	1100	55	498
Lower	2400	2400	84	2000	600	4000	1400	44	635
Extension	2400	2000	84	2000	600	4000	1100	44	545
Manhole Base	2400	2400	115	2100	2000	4000	1200	56	1410
Manhole Base	3000	2400	115	2700	2000	4000	1200	56	1590
Lower	3000	2000	84	2600	600	4000	1100	35	740
Extension	3000	2000	84	2600	600	4000	1100	35	740
Lower	4000	2400	130	3600	600	4000	1400	58	1210
Extension	4000	2000	130	3600	600	4000	1100	58	1140
Lower	5000	2400	181	4500	600	6000	1400	99	2358
Extension	5000	2000	181	4500	600	6000	1092	109	2177
Lower	7200	2400	181	6700	600	6000	1400	36	3660
Extension	7200	2400	181	6700	600	6000	1400	36	3660

Greater widths are achievable subject to kPa loads

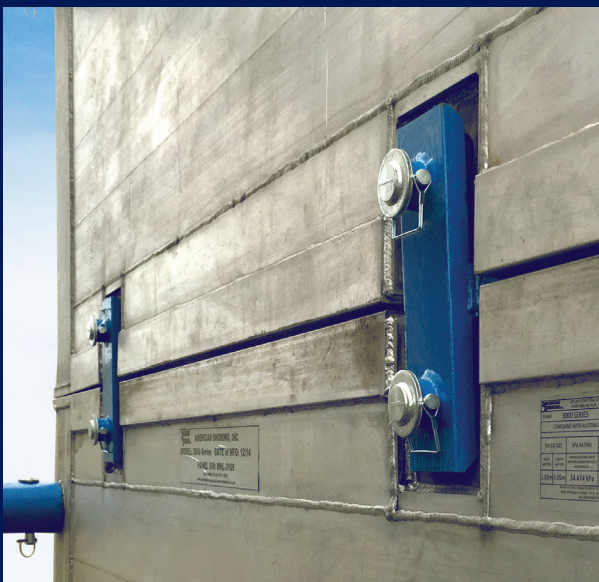

HEAVY DUTY SHIELDS

heavy duty, durable steel shoring

Our Heavy Duty steel shields are designed and built for the toughest ground conditions and maximum internal working clearances.

We have sourced some of the strongest steel fixed panel shields available today.

Our new steel shields are stronger and even lighter than most other competitors. Compare and enquire today!

“Trench shields for the toughest ground conditions and loadings”.

FEATURES & BENEFITS

- Available in panel lengths up to 6.0m
- Manhole Shields available in this range
- Rated to withstand up to 100kPa
- Up to 2.4m under strut clearance with high-clear configuration
- Up to 6.0m internal working widths
- Heavy duty hard wearing knife edge on lower panels for quicker installation
- Reinforced double top and side rails for extra durability



SPECIFICATIONS

Panel Type	Panel Length (mm)	Panel Height (mm)	Panel Width (mm)	Clear Working Dimensions				Safe Working Load (kPa)	Weight (kg)
				Clearance Length (mm) strut - strut	Min Width (mm)	Max Width (mm)	Understrut Clearance (mm)		
Manhole Base	2,400	2,400	104	2,100	1,500	4,000	1,220	103	2,540
Lower	4,000	2,400	104	3,370	600	6,000	1,500	88	3,030
Extension	4,000	2,000	104	3,370	600	6,000	1,040	100	2,720
Lower	5,000	2,400	104	4,370	600	6,000	1,498	60	3,586
Extension	5,000	2,000	104	4,370	600	6,000	1,041	61	3,139
Lower	6,000	2,400	155	5,370	600	6,000	1,625	60	4,630
Extension	6,000	2,000	155	5,370	600	6,000	1,040	62	4,140



MODULAR SHORING

Mabey's Aluminium Modular Trench Shoring systems is a lightweight modular series available with 2-way and 3-way corner posts and a variety of panel widths allowing for easy changes to be made on site to meet the requirements of any job.

FEATURES & BENEFITS

- Smooth wall panel design
- Shield components stack flat for easy transportation
- Exclusive corner end post design allows for either panels or adjustable strut
- Bottom panels may be removed to allow for cross utilities



2-WAY CORNER POSTS

MODEL	LENGTH (mm)	WEIGHT (kg)
MC 48	1219	17.2
MC 72	1829	25.4
MC 96	2438	34.0

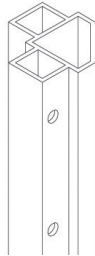

3-WAY CORNER POSTS

MODEL	LENGTH (mm)	WEIGHT (kg)
MC 3-48	1219	23.1
MC 3-72	1829	34.5
MC 3-96	2438	45.8

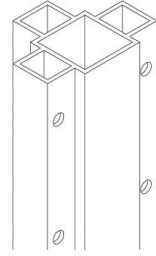

ADJUSTABLE STRUTS

MODEL	MIN LENGTH A (mm)	MAX LENGTH B (mm)
TS 18-26	457	660
TS 23-24	584	863
TS 28-44	711	1117
TS 34-54	863	1372
TS 42-66	1067	1676
TS 52-88	1321	2235

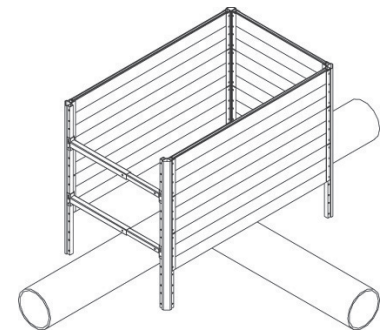
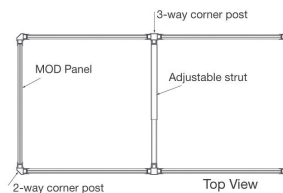
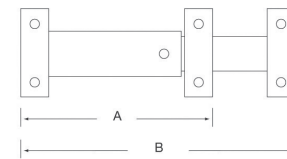

For external box dimensions add an approx. of 152mm

PANEL DEPTH CHART

Panel			Soil Type Maximum Depth of Cut		
HEIGHT (mm)	LENGTH (mm)	WEIGHT (kg)	B (mm)	C-60 (mm)	C-80 (mm)
610	914	22.7	15240	15240	12800
610	1219	27.2	15240	12800	9754
610	1829	40.8	11580	8534	6096
610	2438	54.4	8534	6401	4877
610	3048	63.5	7090	5182	3962

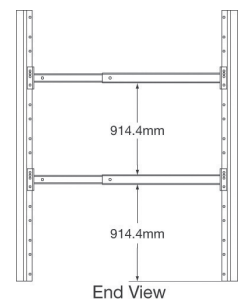

HYDRAULIC VERTICAL SHORING (VERTI SHORES)

A quick, easy, simple way to shore a trench; one person installation and removal from above ground. Mabey's lightweight hydraulic verti shores are constructed from high yield aluminium alloy making them exceptionally strong, durable, portable and versatile.

RAIL LENGTH (mm)	2134
MIN WIDTH (mm)	711
MAX WIDTH (mm)	1930
COMPLETE WEIGHT (kg)	33.5

FEATURES & BENEFITS

- Cylinder pads mount flush, providing even load distribution on side rails
- One-piece cylinder extensions can be installed easily at the job site to accommodate a variety of trench widths to max of 1930mm
- Cylinder oversleeves are standard and provide extra strength whilst protecting the cylinders
- Bleed-off ports eliminate over-extension of cylinders to increase safety
- Hinged design allows for fast removal and easy transportation
- Recommended max distance between rails 1500mm – subject to ground conditions

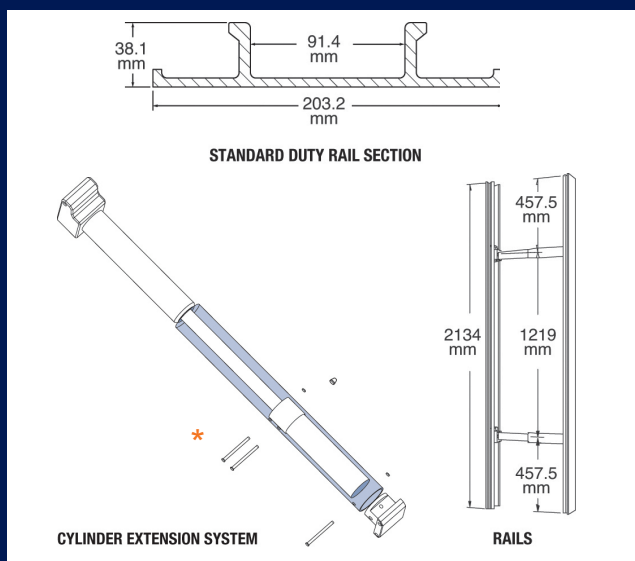

*to maximum width of 760mm

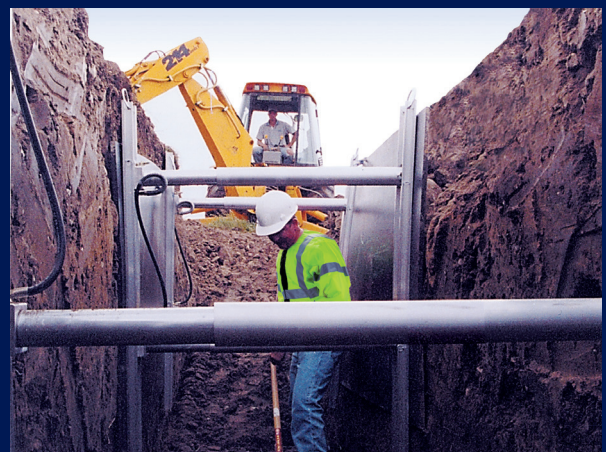

SHORING ACCESSORIES

Using a Mabey trench shield system to shore your trench excavation and protect your workforce is an important first step in delivering a safe work environment. We also carry a range of additional products designed to work with the trench shield system to improve trench access and safety.



STRUTS



- Fixed width sizes for maximum strength and minimal damage
- Pinned to shields, not bolted for quick installation and interchanging between sizes
- Available in sizes from 600mm to 4000mm (Ultra Shields)
- Available in sizes from 600mm to 6000mm (Versa & Heavy Duty Shields)



LIFTING CHAIN

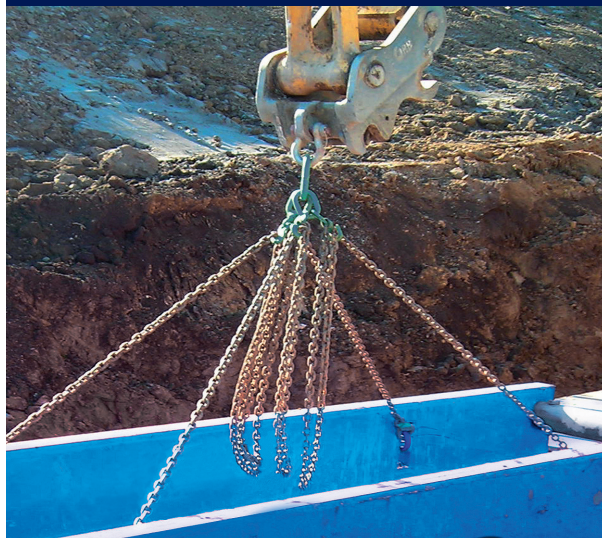

- 8mm and 10mm four leg lifting chains designed for safe lifting, assembly and disassembly of the Ultra and Versa Shields
- 13-16mm four leg lifting chains designed for safe lifting, assembly and disassembly of the Heavy Duty Shields



LADDER MATE SYSTEM



- Safer access to and from the excavation
- Lightweight cantilevered platform designed for use on most of our trench shield systems
- Supports up to 4m long ladder access (ladder not supplied)
- Rated to 500kg SWL



TRENCH SHIELD HANDRAIL



- Trench fall arrest/edge protection
- Budget range available in 2.4m and 4.0m lengths
- Premium range available in 3.0m and 4.0m lengths
- Easy fit footings securely fasten to all Mabe trench shield systems



DAVIT ARM



- Fixed width sizes for maximum strength and minimal damage
- Pinned to shields, not bolted for quick installation and interchanging between sizes
- Available in sizes from 600mm to 4000mm (Ultra Shields)
- Available in sizes from 600mm to 6000mm (Versa & Heavy Duty Shields)



EXTENDED WALKWAY

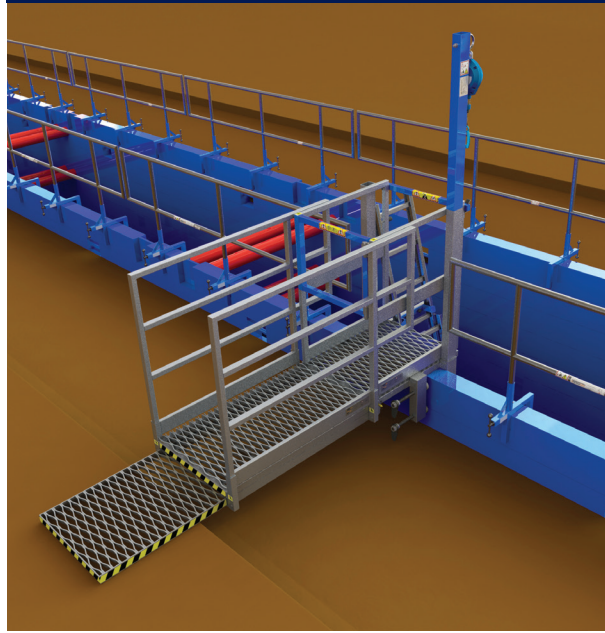

Hire a walkway to provide safe pedestrian access over open trenches. Mabey offers a range of open-trench walkways and trench bridges to improve access for pedestrian traffic and heavy vehicles around your project or event.

- 6m low profile design
- Lockable gates at each end
- Rated to 500kg SWL
- No onsite assembly required
- Simple anchoring detail.





HIGH CLEAR ARCHES

- Designed to maximise under strut clearance without compromising rated work loadings
- Available with under strut clearance of 2400mm and internal width from 1500mm to 4000mm (for Heavy Duty and Versa Shields)

HIGH CLEAR ARCHES FOR ULTRA SHIELDS



HIGH CLEAR ARCHES FOR VERSA SHIELDS



HIGH CLEAR ARCHES FOR HEAVY DUTY SHIELDS



TEMPORARY GROUND PROTECTION



Avoid significant ground repair or rehabilitation costs to eco-sensitive or heritage sites around your project

Mabey's range of safe, durable temporary ground protection systems. Designed for improved access for anything from pedestrian traffic at events, to heavy vehicle movements on site. Mabey has a ground protection system to do the job.

KEY APPLICATIONS AND ENVIRONMENTS WHERE GROUND PROTECTION IS IDEAL:

- 1. Civil, commercial & residential construction:** improve access to sites in all weather conditions, prevent vehicle bogging and reduce soil spills on sealed roads. Provide plant and machinery access through eco sensitive areas.
- 2. Outdoor events/festivals:** provide safe pedestrian and vehicle access while protecting lawns, stadium turf and other sensitive ground types.
- 3. Utilities/Energy:** provide safe access roads or temporary work hardstand areas for heavy machinery on HV transmission line builds, wind farms or oil & gas pipeline construction sites.
- 4. Property maintenance:** protect existing lawns and precious sealed surfaces from heavy plant and site traffic around buildings and other structures requiring maintenance.
- 5. Special events:** improved access and ground protection for temporary film sets on location, aircraft taxiways, multisport events and car shows.

TUFFTRAK

Avoid significant ground repair or rehabilitation costs to eco-sensitive or heritage sites around your project or event by hiring from Mabey's range of safe, durable temporary ground protection systems. Designed for improved access for anything from pedestrian traffic to heavy vehicle movements Mabey has a ground protection system to do the job.



EURO MAT

EuroMat is the market leading access mat ideal for providing ground protection and temporary access for lighter vehicles and pedestrians. EuroMat is chemically inert and can be used on sensitive sites and will withstand erosion from chemical treatments.

EuroMat is manufactured from 100% premium recycled high density polyethylene (HDPE) or virgin HDPE and is a lighter weight option than the TuffTrak at only 35kg per mat.



FEATURES & BENEFITS

- Environmentally friendly: made from 100% recycled material, and significantly reduces ground damage and post works rectification requirements
- Prevents vehicle bogging on soft ground
- Preserves eco-sensitive work sites and minimises the risk of soil contamination
- Chemically inert. Won't react with oils, fuel and all other acids, alkalis or solvents
- Non-conductive, particularly important on power line and HV transmission construction projects
- Weatherproof. Mats won't warp or crack in sunlight and won't absorb water
- Supports vehicle loading up to 80t

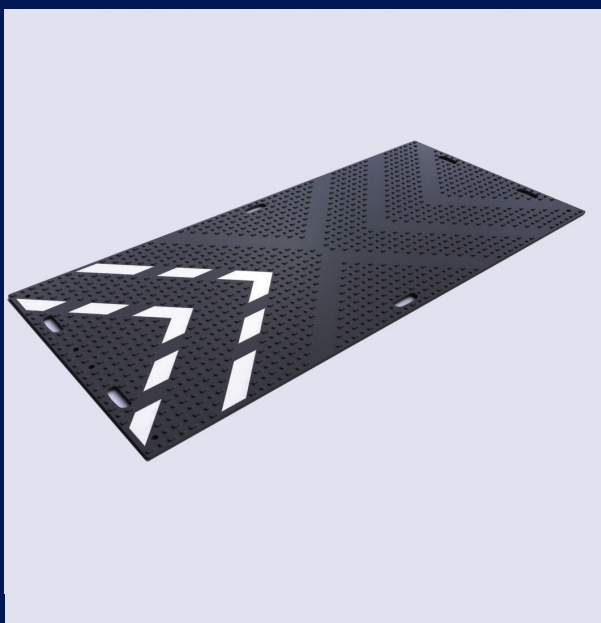

MAT SPECIFICATIONS

	Mabey TuffTrak	Mabey Euro Mat
Thickness	40mm	12mm
Dimensions	3000mm x 2500mm	2410 x 1200
Weight	290kg	35kg
Capacity	150t	80t
Material	Premium recycled or virgin high density polyethylene (HDPE)	Premium recycled or virgin high density polyethylene (HDPE)
Connectivity	Drop in bolt system – metal connectors for heavy and tracked equipment	Standard connectors - 2 way & 4 way



HYDRAULIC BRACING

Beyond trench excavations and shoring, sheet and frame systems (or hydraulic bracing) are ideal shoring solutions for larger rectangular or irregular shaped excavations such as underground tank installations, multi-service connection areas like water treatment plants or electrical substations and commercial building groundworks.

MULTIBRACE

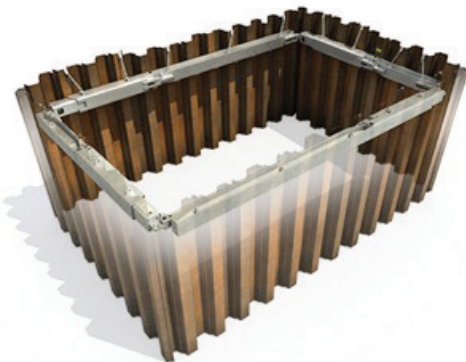

- Standard frame assemblies cover excavations from 2.5m to 10.3m sheet to sheet
- Cross bracing struts are easily connected to the frame to increase length and strength of the system
- Pinned corners allow bracing of non-square excavations.
- Multibrace System connects to Super Shaftbrace system with interchangeable component design

SUPER SHAFTBRACE

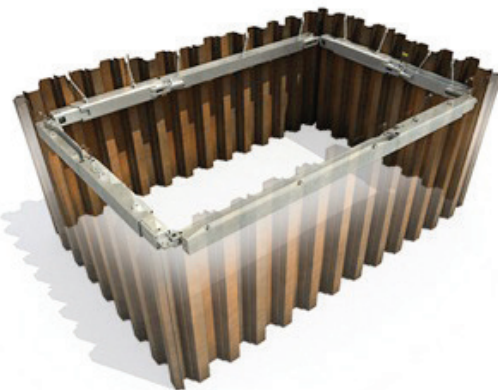

- Standard frame assemblies cover excavations up to 16m x 16m
- Cross bracing struts are easily connected to the frame to increase length and strength of the system
- Pinned corners allow bracing of non-square excavations
- Super Shaftbrace system connects to Multibrace system with interchangeable component design

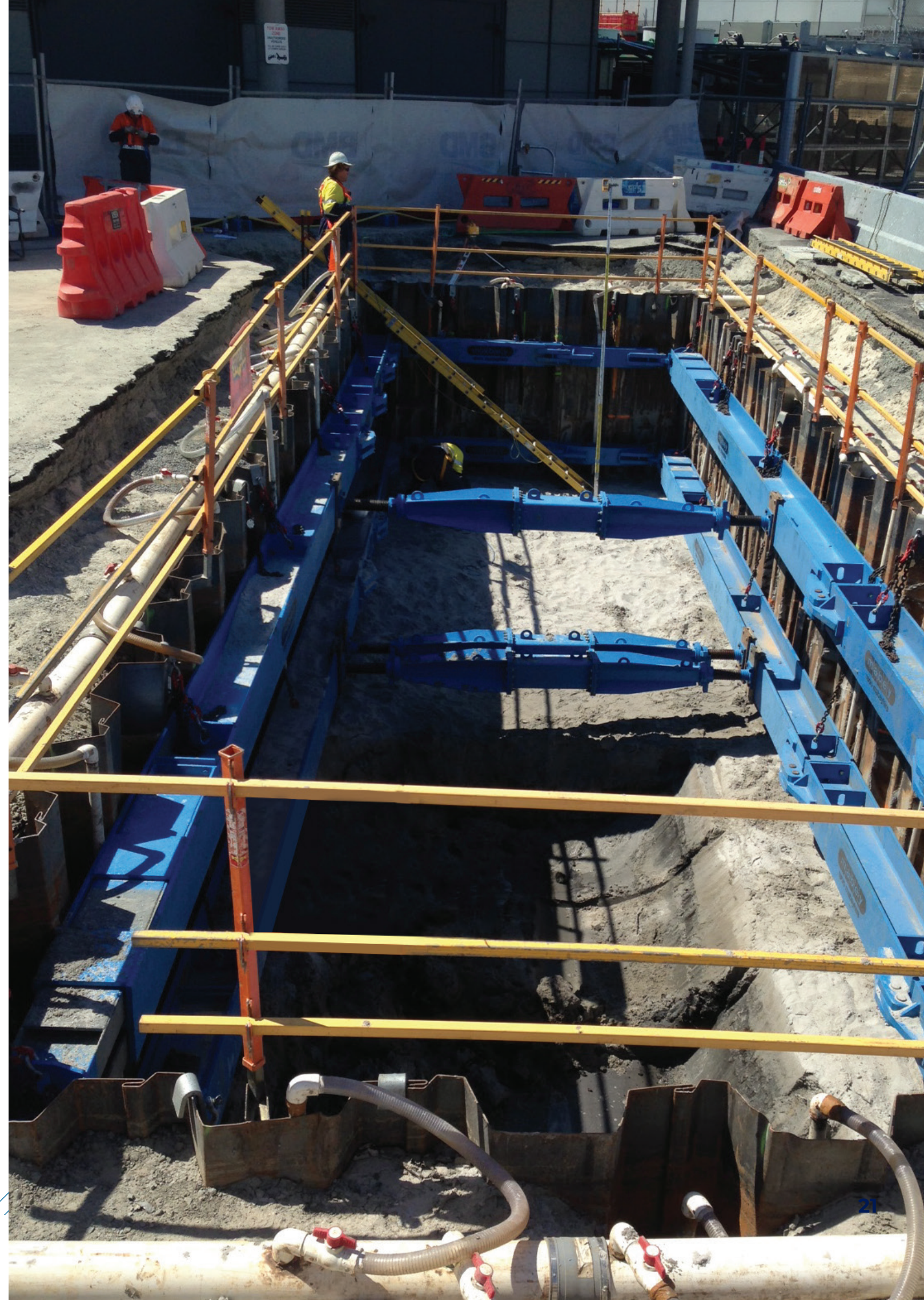

TRENCH SHEETS SHEET PILING & EMV

Our range of sheeting is designed to cover a range of uses in both temporary and permanent works

The overlapping range can be used for a wide range of applications from digging and placing of short sheets in shallow excavations, to full driving in deep excavations.

The interlocking range can be used for applications ranging from shallow riverbank protection to deep, large area cofferdams.

All pile sections have a top lifting hole to assist with install and extraction and are well matched for use with our hydraulic support systems.

Most sections are available for hire and for sale.

WE OFFER

- 6mm overlapping trench sheet profile
- 7mm and 11mm interlocking sheet profile
- Sheet pile driving caps available
- Sheet extractor tools available
- Excavator mounted vibrating machines available (EMV)

INTERLOCKING SHEET PROFILE

Product Name	Dimensions				Properties				
	W (mm)	H (mm)	TF (mm)	TW (mm)	Weight per linear metre (kg)	Weight per square metre (kg)	Section Modulus per metre of wall (cm ³ /m)	Bending Moment (WLL) - FOS OF 1.5 (kNm/m)	Steel Grade
NS - SP - 10H	900	230	10.8	10.8	86.4	96	902	235	S390

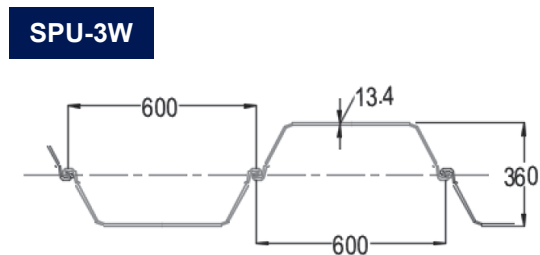
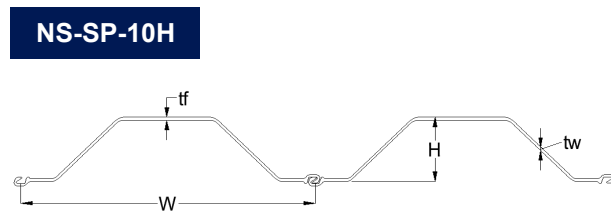

Product Name	Dimensions				Properties					
	W (mm)	H (mm)	TF (mm)	TW (mm)	Weight (kg/m)	Weight(kg/m ²)	Moment of Inertia (cm ⁴ /m)	Section Modulus (cm ³ /m)	Moment Capacity (WLL) - FOS of 1.5	Steel Grade
SPU-3W	600	360	13.4	13.4	81.6	136	32400	1800	426	S355

OVERLAPPING SHEET PROFILE SPECIFICATIONS.

Product Name	Dimensions				Properties				
	W (mm)	H (mm)	TF (mm)	TW (mm)	Weight per linear metre (kg/m)	Weight per square metre (kg/m ²)	Section Modulus per metre of wall (cm ³ /m)	Bending Moment (WLL) -FOS OF 1.5 (kNm/m)	Steel Grade
M12	550	87.5	6	6	32	58.2	182	42.7	HA 350
MH5-750	750	250	4	4	37.5	50	510	107.8	

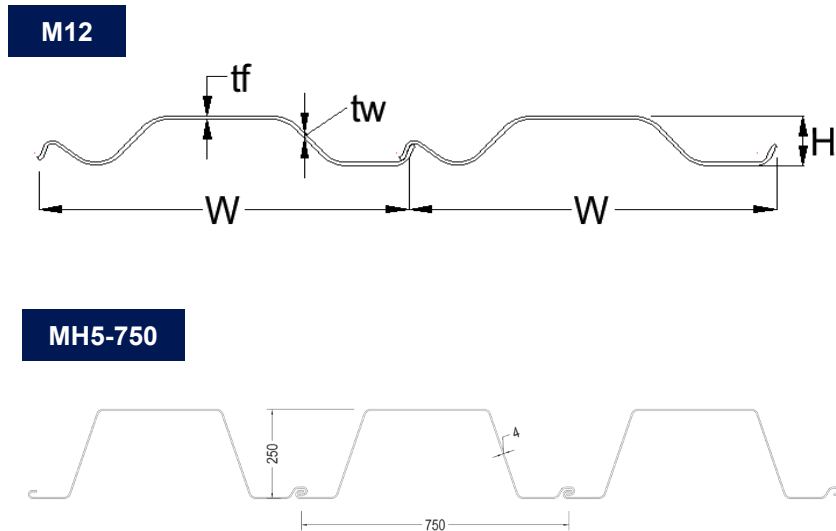

EXCAVATOR MOUNTED VIBRATOR (EMV)

Mabey's excavator-mounted vibrator (EMV) attaches directly to your excavator to assist in the safe and efficient installation and extraction of sheet piles. Localised directional vibration keeps soil disturbances to a minimum. The next time you are driving sheets, save time and the surrounding infrastructure by using Mabey's EMV.

- The EMV 300 model has a compact design with a high power to weight ratio
- Heavy duty 450 model provides up to 450kN of centrifugal force
- Both models connect to your excavator regardless of machine type with no need for additional adjustments or fittings



STEEL ROAD PLATES

The quickest and most cost-effective way of providing safe vehicle, plant and people access over temporary open trenches or manholes. Typical applications include: road excavation coverings for safe vehicle passage; site access or driveway crossings and for use as trench shield end plates to reduce soil in-fill from the trench.

We carry eight common sizes with a span of up to 6m. The plates can be coated and coloured with non slip paint to suit Australian road specifications as required by local road authorities. Our range also includes easy-lift centre point lifting and 32mm thick road authority approved plates.



SPECIFICATIONS

Length (mm)	Width (mm)	Plate Thickness (mm)	Weight (kg approx)
2400	1200	25	565
3000	1200	25	706
3000	2400	25	1412
3000	2400	32	1815
4000	1800	32	1815
4000	2400	25	1883
4000	2400	32	2420
6000	2400	25	2824



TEMPORARY BRIDGING



We're proud to introduce the Compact 200™ (C200™) steel panel bridging system to Australia and New Zealand. C200™ is Mabey's most widely used modular bridging product and is suitable for both temporary and permanent applications. With a heritage stretching back over 70 years to the original Bailey Bridge system, our compact bridge's extensive use worldwide pays testament to its reliability and versatility. The compact bridge system uses standard, interchangeable steel components to provide robust, rapidly deployed and erected solutions for; permanent bridges, temporary bridges, rural bridges, access bridges, footbridges and emergency and contingency bridging applications. Emergency and contingency bridge stocks, held in country, allow for immediate availability when needed.

The C200™ can carry up to two lanes of traffic, with options for external cantilevered foot walks, and can be configured as a single or multiple span bridge. Multi-span solutions are supported on intermediate piers, meaning that there is no limitation to the length the C200™ can bridge. This makes it a versatile solution suited to a wide range of applications. Floating bridge solutions, using pontoon systems and bespoke connections, have also been achieved, as well as jetty applications for ferry and barge access. The C200™ can also be adapted to serve as pipe or utility support bridges suited to carrying, for example, oil, water, gas pipes, conveyors and other services and is the most adaptable and versatile solution in the Mabey range.

KEY BENEFITS

- Modular for easy transit
- Pre-engineered design – no bespoke engineering costs
- Rapidly assembled and installed
- Achieves longer unsupported spans than most other bridging methods – minimize your substructure costs and stay out of waterways
- Crane installation or cantilever launch options
- Compact bridges are relocatable
- Robust, Long life with minimal maintenance
- Single and multi-span compact bridges can be achieved
- Separate pedestrian walkways can be cantilever mounted to vehicle bridges

KEY APPLICATIONS

- Bridging temporary haul roads and creek crossings
- Bridge maintenance/restoration works
- Improve project safety by re-routing traffic off permanent structures under repair
- Maintaining trafficable routes while permanent bridge structures are built
- Emergency and contingency bridging support
- Rural bridge replacement
- Temporary staging
- Event access
- Utilities bridging

SPECIFICATIONS

Module Length	3.048m
Carriageway Widths	2.1m for pedestrians; 4.2-7.35m for vehicles
Number of Lanes	1 or 2
Cantilever pedestrian walkways	Up to 1.5m wide
Finish	Hot-dip Galvanised: BS EN ISO 14713 & 1461 ASTM A123

Bridge trusses are the main load-bearing elements of a bridge and are constructed from Panels and Reinforcing Chords plus, for Single constructions, Rakers and, for multi-panel line constructions, Vertical Frames, Bracing Frames and Tie Beams.



SINGLE LANE ROADWAYS

SPAN = NUMBER OF BAYS X 3048MM

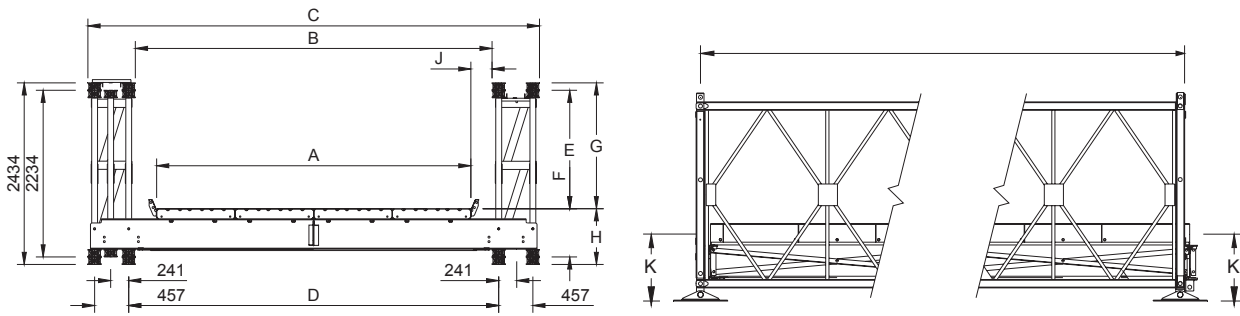

TWO LANE ROADWAYS

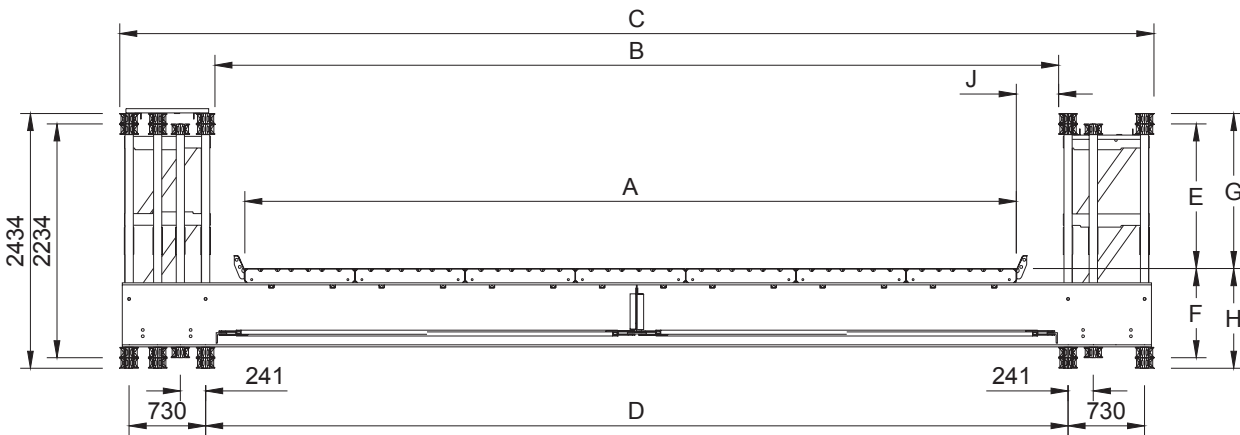

Dimensions	Clear Working Dimensions		Two Lane Roadways
	Standard Width 3.15m	Extra Wide 4.20m	7.35m
A	3150	4200	7350
B	3759	4775	8052
C*	5029	6045	9868
D	3937	4953	8230
E	1590	1587	1381
F	644	647	853
G	1690	1687	1481
H	744	747	953
J	304	287	351
K	802	805	1011

* For single truss constructions the nominal overall widths are 4964mm, 5980mm and 9820mm for Standard Width, Extra Wide and Two Lane Roadways respectively.

VALUE ADDED SERVICES



DEDICATION

Mabey account management

You're not just another customer number, you're a valued client we want to serve. That's why we have a team of Sales Representatives dedicated to managing your account and improving our service. This means your Sales Representative is available to you to consult on site problems or challenges; advise on site specific solutions; actively plan and optimise your equipment hire (while minimising your costs); update you on new products or services; act on your feedback good or bad and generally take care of all the little details you expect will be taken care of when you need a groundworks solution.

Not sure of your requirements, or perhaps you're unfamiliar with shoring techniques? Contact a Mabey branch near you and arrange for one of our friendly Sales Representatives to provide you with a site demonstration or general discussion and introduction on our product capabilities.

RELIABILITY

Mabey transport services

We own a fleet of trucks and specialised delivery vehicles available at every branch location. Operated by accredited and experienced drivers we strive to maintain the tightest control over site deliveries and pickups to provide a reliable service and minimise unplanned downtime on site.





Most branches also operate crane trucks to minimise client material.

ASSURANCE

Mabey engineering services

If you have an engineering question about your groundworks project, or you require structural design plans for your shoring, bracing or propping project, then let our experienced in-house engineers provide that assurance. We'll check structural integrity based on the best site information available to provide a safe solution that will meet Australian and New Zealand standards.

Our engineers will engage you and our staff to select, design and test the optimal groundworks solution for your project.

CONVENIENCE

Mabey pre assembly services

Short on site labour and time? Don't forget to request your next order of shoring shields to be fully assembled and ready to install prior to delivery. Check with your local branch for availability.

FLEXIBILITY

Mabey sales

If hiring a trench shoring or ground protection system is not feasible for your project or long term business requirements, or you require a unique, custom-made solution not readily available in the hire market then talk to us about purchasing a system outright.

CONVERSIONS TABLE

Physical Quantity	Si unit	Measurement	Conversion
Area	Square Metre (m ²)	Square Metre (m ²) - Square Foot (ft ²) Square Foot (ft ²) - Square Metre (m ²) Square Millimetres (mm ²) - Square Inch (in ²) Square Inch (in ²) - Square Millimetre (mm ²)	1m ² = 10.76ft ² 1ft ² = 0.092m ² 1mm ² = 0.001in ² 1in ² = 645.2mm ²
Density	Kilogram Per Cubic Metre (kg/m ³)	Kilogram Per Cubic Metre (kg/m ³) - Pound Per Cubic Foot (lb/ft ³) Pound Per Cubic Foot (lb/ft ³) - Kilogram Per Cubic Metre (kg/m ³) Kilogram Per Cubic Metre (kg/m ³) - Kilonewton Per Cubic Metre (kN/m ³) Kilonewton Per Cubic Metre (kN/m ³) - Kilogram Per Cubic Metre (kg/m ³)	1kg/m ³ = 0.0624lb/ft ³ 1lb/ft ³ = 16.02kg/m ³ 1kg/m ³ = 0.0098kN/m ³ 1kN/m ³ = 101.9kg/m ³
Length	Metre (m)	Metre (m) - Foot (ft) Foot (ft) - Metre (m) Millimetre (mm) - Inch (in) Inch (in) - Millimetre (mm) Kilometre (km) - Mile (mi) Mile (mi) - Kilometre (km)	1m = 3.28ft 1ft = 0.305m 1mm = 0.039in 1in = 25.4mm 1km = 0.621mi 1mi = 1.609km
Mass	Kilogram (kg)	Kilogram (kg) - Newton (N) Newton (N) - Kilogram (kg) Kilogram (kg) - Pound (lb) Pound (lb) - Kilogram (kg) Tonne (t) - Kilonewton (kN) Kilonewton (kN) - Tonne (t)	1kg = 9.81N 1N = 0.102kg 1kg = 2.2046lb 1lb = 0.4536kg 1t = 9.81kN 1kN = 0.102t
Pressure	Pascal (Pa)	Pascal (Pa) - Newton Per Square Metre (N/m ²) Kilopascal (kPa) - Kilonewton Per Square Metre (kN/m ²) Megapascal (MPa) - Kilonewton Per Square Metre (kN/m ²) Bar (bar) - Kilopascal (kPa) Kilopascal (kPa) - Pound Per Square Inch (psi) Pound Per Square Inch (psi) - Kilopascal (kPa)	1Pa = 1N/m ² 1kPa = 1kN/m ² 1MPa = 1000kN/m ² 1bar = 100kPa 1kPa = 0.145psi 1psi = 6.89kPa
Volume	Cubic Metre (m ³)	Cubic Metre (m ³) - Cubic Foot (ft ³) Cubic Foot (ft ³) - Cubic Metre (m ³) Cubic Metre (m ³) - Litre (L) Cubic Metre (m ³) - Gallon (gal) Gallon (gal) - Cubic Metre (m ³) Litre (L) - Gallon (gal) Gallon (gal) - Litre (L)	1m ³ = 35.31ft ³ 1ft ³ = 0.028m ³ 1m ³ = 1000L 1m ³ = 219.96gal 1gal = 0.0037m ³ 1L = 0.264gal 1gal = 3.785L



While information in this Guide is correct at time of printing, product specifications and product availability are subject to change without further notice. Please visit our website for the most up to date information. Job site photos are strictly intended for general product illustration only and may not comply with all applicable safety standards or site requirements. Specification data has been taken from manufacturers' serialised specific tabulated data.

1800 622 394

www.mabey.com.au