

PRODUCT USER GUIDE

EXCAVATOR MOUNTED VIBRATOR - EMV

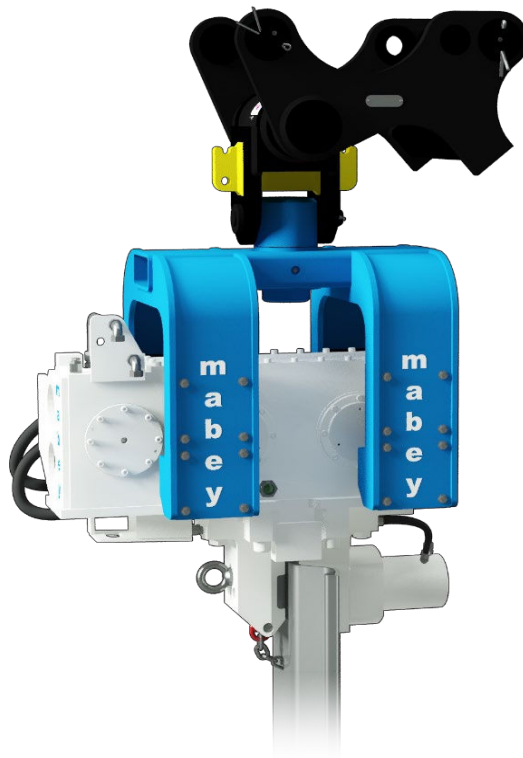

Introduction

This booklet is intended to provide basic information for users of the Mabey Hire Ltd Pty Excavator Mounted Vibrator (EMV) and to draw the client's attention to the practical aspects of EMV operational procedures and basic maintenance which need to be considered when compiling method statements, risk assessments and safe system of works. It is not intended to be an exhaustive detailing of the manufacturer's detailed knowledge of the product. It is assumed that clients are familiar with general safe practices applicable to this type of work.

The EMV system is intended to be used as a tool to readily convert any suitable size excavator into a highly productive pile driving machine. Piles can be lifted from a stack on the ground, engaged into a powerful hydraulic grip then positioned at will for vibrating into the ground. It is not intended for other purposes. It is advisable, before commencing installation, to read the notes below and to become familiar with the procedures involved when using the EMV.

The EMV should not be used in seawater applications without prior consultation with the Mabey Hire Ltd Pty. Department.

EMV Available

- ▶ EMV - 300
- ▶ EMV - 450
- ▶ ABI HVR - 60

IMPORTANT NOTES

All excavation work must be thoroughly planned before work commences on site to identify hazards and assess risk.

These instructions form guidance for the typical use of EMV piling equipment. Non-standard applications should be approved by a suitably qualified person.

Ensure all personnel engaged in installation operations are properly briefed and adequately supervised by a competent person.

WWW.MABEY.COM.AU

AUS: 1800 622 394

NZ: 0800 622 394

Uncompromising Service
to Deliver Successful
Projects

Contents

1. General Guidance Notes	3
▶ Safe System of Work and Method Statement	3
▶ Access, Hardstanding Areas and Site Storage	3
▶ Personnel	3
▶ Plant and Lifting Equipment	3
▶ Transportation	3
▶ During Installation Works	3
▶ After Installation Works	3
▶ Return of Equipment Off-Hire	3
2. Design	4
3. Component Identification	4
▶ EMV Identification and Specifications	4
▶ Mabey Fully Adjustable Quick Hitch	5
▶ Lifting Chain	5
▶ EMV Stand	5
4. Connection Details and Site Assembly	6
▶ Important Note	6
5. Operating Procedure Details	7
▶ Preliminaries	7
▶ Installing Piles	7
▶ Removing Piles	8
▶ Piling Refusal and Rebound	8
6. Basic Maintenance	9
▶ Preliminaries	9
▶ Daily Maintenance / Checks	10
7. Important Points	11
▶ Basic Safety Points	11
▶ Responsibility	11
8. General	11
Appendix A - Warnings	12
Appendix B - Proof of Inspection Form	13
Appendix C - Provision of a Mabey Hire Ltd Pty. Site Fitter	16
Appendix D – Check List EMV	17

1. Guidance Notes

Safe System of Work and Method Statement

Assuming that the appropriate Excavator Mounted Vibrator has been selected for use, the Health and Safety at Work Act requires that a safe system of work is adopted to carry out the works on site.

These guidance notes are intended to draw the client's attention to practical aspects of Mabey Hire Ltd Pty. range of Excavator Mounted Vibrator components during use and basic maintenance which need to be considered when completing method statements for a safe system of work.

Access, Hardstanding Areas and Site Storage

- Suitable firm, level, dry areas should be made available on site for storage and pre-assembly work.
- Suitable lifting equipment of adequate capacity should be provided for off-loading and installation.
- Slings should always be carried out by suitably experienced and competent personnel.
- The weights of components and assemblies are given in Section 3 of this guide.
- Large components should be stacked, nested with suitable timber dunnage.
- Smaller components should always be stored in skips/bins.

Personnel

The Management of Health and Safety at Work Regulations require that personnel deployed are suitably trained, experienced and supervised by a competent person. All lifting operations are to be controlled by an appointed person in accordance with regulations.

WARNINGS:

- If Excavator Mounted Vibrator components are to be lifted in or around an excavation, the appliance should be located at a safe distance from the edge of the excavation and the lifts and radii checked against the safe lifting capacities of the appliance.
- A surcharge for the appliance must have been allowed for in the excavation brief / design.

Plant and Lifting Equipment

A suitable appliance is required for off-loading, installation, and re-loading of equipment, together with lifting chains of suitable length and capacity and with current certification.

Transportation

In Transit

When transporting the vibrator, ensure it is placed correctly in the stand. Once in place on the stand, the jaws must be closed. Release the hydraulic hoses from the excavator (the hard jaws will remain closed) and cap the hose ends to prevent contamination. Disconnect the vibrator from the excavator.

When transporting the EMV connected to the stand, always keep the load close to the ground, i.e. **DO NOT** lift or transport over personnel. Ensure all equipment is loaded to the satisfaction of the vehicle driver and is securely restrained to the vehicle bed.

On Site

Transporting a pile using the vibrator should only be done over a short distance, with the clamp fully engaged on the pile top and with the lifting chain fitted. Should the grip on the pile be reduced during this procedure, the excavator must stop, and a better grip effected. Should a pile slip then the lifting chain could snap and cause an accident.

When transporting a pile extreme care must be taken to ensure that no one is in the Danger Area and that the pile is handled in such a way as to ensure no danger to site personnel at any time. Care should be taken at all times to ensure the lifting chain does not become snagged in the jaws of the EMV and that the Chain Clamp is a minimum of 6 links from the bottom of the chain.

In order to avoid extensive transporting, have the piles laid out as close to the point of installation as possible. Do not use the excavator with the EMV installed to handle bundles of piles around the job site. Sheets must not be dragged into position using the chain.

During Installation Works

- Check that all bolted connections remain tight.
- Check that all pinned connections are intact wherever required.
- Avoid striking equipment or loading it inappropriately, i.e. laterally loading it by storing materials or by handing or propping from them.

-After Installation Works

Each excavation must be inspected daily before personnel begin work.

-Return of Equipment Off-Hire

Clients should ensure that on removal, the equipment is returned clean and assembled as supplied.

2. Design

Hydraulic power supply is taken from the excavators auxilliary circuit, providing adequate power is available. Other than the addition of a small drail line directly back to the excavators tank, there are no other special modifications to the base machine and no electrical system is required. The operator uses standard controls.

Maximum pile lengths are determined by excavator boom length, but typical pile lengths are up to 7m (with caution), see Section 4.1 for maximum pile weights.

As a guide, EMVs typically suit the following base machine sizes:

EMV	Excavator Te.	
	Min	Max
ABI 60	25	45
EMV-400	25	45
EMV-450	25	45

3. Component Identification

3.1 EMV Identification and Specifications

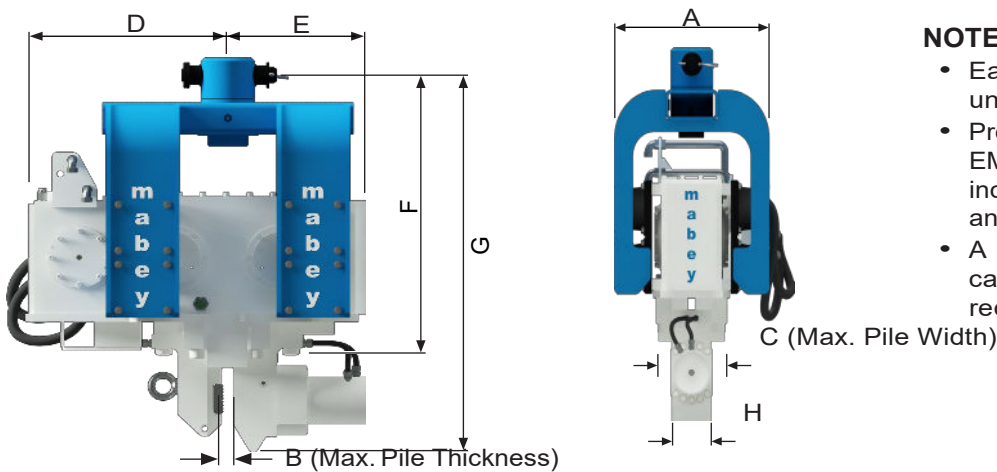

NOTES:

- Each EMV has its own unique item number
- Product codes ABI-60, EMV-400 and EMV-450 include a Standard Bracket and Stand.
- A Quickhitch Bracket can be supplied upon request.

Excavator Mounted Vibrators

SPECIFICATION		ABI HVR- 60	EMV-300	EMV-450
Dimensions	A	615	615	615
	B		25	32
	C		250	230
	D	650	582	640
	E	520	429	510
	F	820	927	945
	G	1200	1200	1250
	H		150	175
Static Moment (kgm)		6	4.6	6.9
Frequency (rpm)		2460	2400	2460
Centrifugal Force (kN)		400	300	453
Amplitude - Peak to Peak (mm)			14.7	13.7
Minimum Required Flow Rate (L/min)		196	130	195
Maximum Allowable Flow Rate (L/min)			250	350
Minimum Hydraulic Pressure (Bar)			280	270
Maximum Hydraulic Pressure (Bar)		320	350	350
Minimum Hydraulic Power (kW)		100	60	88
Dynamic Mass (kg)		950	625	1008
Total Mass (kg)		1300	965	1275
Maximum Pile Mass (kg)		1500	800	1000
Maximum Push / Pull Loading (kg)			15000	15000
Clamp Force (Tonne)		40	36	54

3.2 Mabey Fully Adjustable Quick Hitch

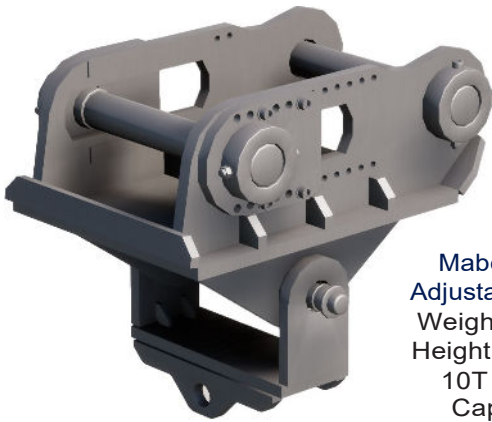

Mabey fully Adjustable Hitch
Weight: 576kg
Height: 865mm
10T Lifting Capacity



Adjustable Hitch pin
Available
Pin: 65Ø, 80Ø, 90Ø & 100Ø
Length: 700mm

3.3 Lifting Chain

Chain Clamp to be a minimum of 6 chain links from the bottom before use

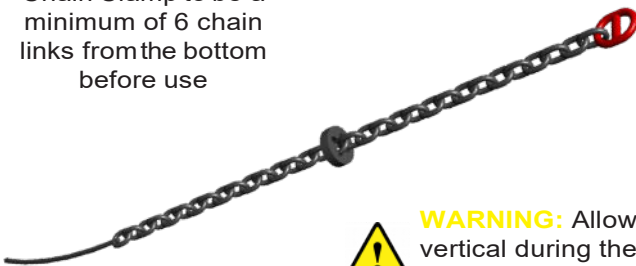

Lifting Chain c/w with Chain Clamp
Weight: 2.9 kg



WARNING: Allow enough free chain length for the pile to rotate to vertical during the lifting process without jamming against the underside of the Clamp Body. If this happens the chain will be overloaded, may subsequently break and allow the pile to fall. This is a severe hazard to **ALL** site personnel and must be avoided at **ALL** times.

3.4 EMV Stand



EMV Stand Code:
NOCODE
Weight: 142 kg

NOTES:

- Lifting chains and Chain Clamps have the same item numbers alternative Quickhitch maybe available to different branch location, speak to your local depot for details.
- If a Large Quickhitch Bracket is required due to the machine size, it is fitted directly to the EMV.

4.0 Connection Details and Site Assembly

4.1 Important Note

 Fitting the EMV to the excavator should ideally be carried out by a Mabey Hire Ltd Pty. employee. Incorrect installation can result in expensive damage to both EMV and excavator. If self-fitting the below is to be adhered to:

Auxiliary hydraulic circuit of excavator must have:

- ▶ Bidirectional flow capability
- ▶ Hard lines
- ▶ Screw on coupling & case drain
- ▶ All fitting must be unrestricted

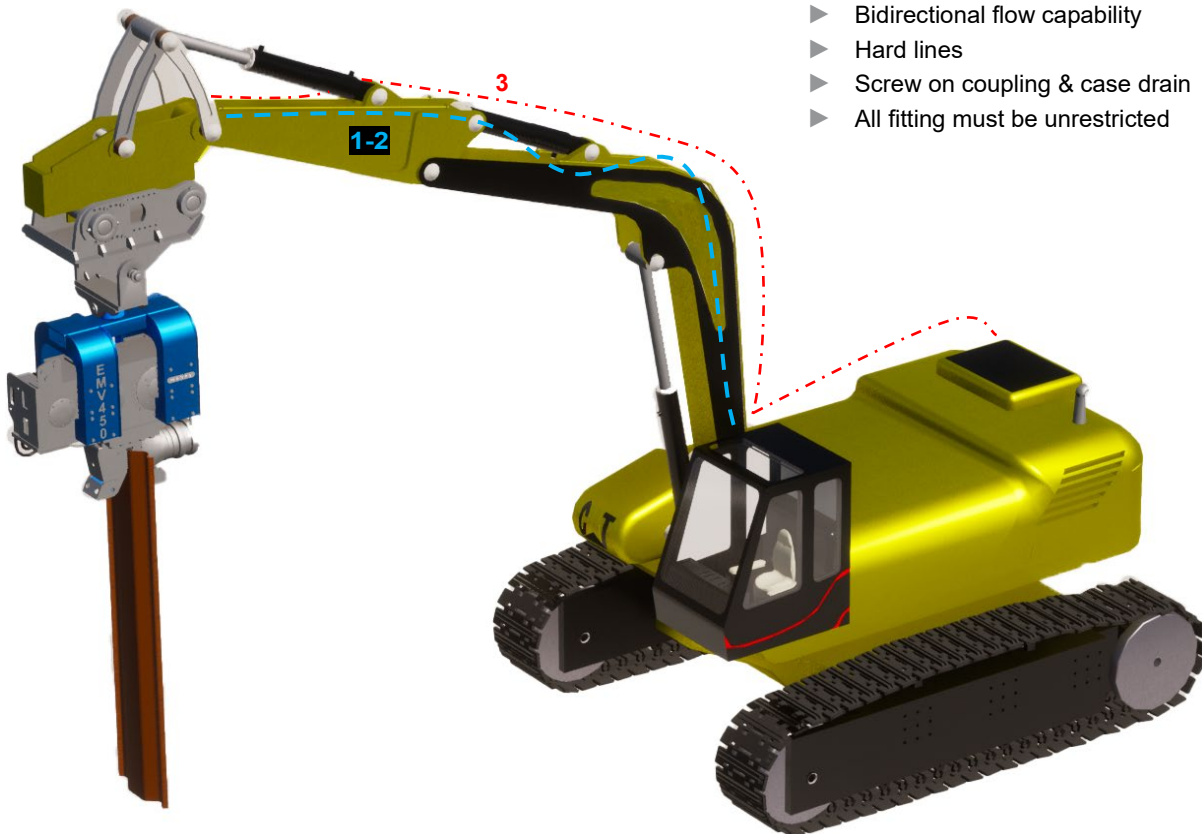

Physical connection:

Suggest using Mabey Fully Adjustable Quick Hitch which is suitable for 20-50T excavators

Mabey require the following information: -(See Pag. 17)

- ▶ Couple pin centres (mm)
- ▶ Couple Pin sizes (mm)
- ▶ Distance between ears (mm)

Hydraulic Connection

There are 3 hoses that require attachment. See image.

1. The Pressure Line- Connected to the bucket ram "Extended" circuit.
2. The Return Line- Connected to the bucket ram "Retracted" circuit.
3. The Drain Line- Fed either directly back into the hydraulic tank on the excavator or connected to the breaker circuit return line (must be unrestricted).

5.0 Operating Procedure Details

5.1 Preliminaries

It is the excavator operator's responsibility to ensure that the machine is functioning and performing correctly. In order to meet this responsibility please note the following points:

- Allow the excavator engine to warm up, particularly in temperatures below 10°C.
- Before work commences, it is particularly important that the vibrator is allowed to run freely for approximately 30 seconds, this allows the gearbox oil to reach all the necessary lubricating points.
- Screws, bolts & connections are often loosened through the vibration of the machine. Check for looseness daily.
- Pay daily attention to the general condition of the hard jaws (vibrator clamp). Ensure they are replaced once signs of wear are apparent.
- Check both the vibrator and auxiliary equipment for damage. Eg. On the lifting chain. Any defects should be immediately notified to the person in charge. **DO NOT** operate a damaged unit.
- It will be apparent from the noise during vibration whether the clamp cylinder has closed tightly. If it has not, check operation of the clamp off the pile top.
- It is imperative that you ensure that during a piling operation the vibrator is kept directly above and in line with the pile, otherwise the piling energy is transferred to the excavator arm and causes unnecessary wear.
- If the pile reaches premature refusal, then it will be necessary to loosen up the ground, possibly through drilling. Under **NO CIRCUMSTANCES** should the pile be forced further. Alternatively, a larger piling device should be used, see Section 6.4 for details.

5.2 Installing Piles

- Ensure that all safety procedures and maintenance have been carried out before starting the excavator.
- Check that it is safe to move the dipper arm. Release the stand from the jaws of the vibrator and manoeuvre the vibrator above one end of the pile to be pitched so that there is enough distance to allow safe insertion of the lifting chain through the hole at the top of the pile.

WARNING: Allow enough free chain length for the pile to rotate to vertical during the lifting process without jamming against the underside of the Clamp Body. If this happens the chain will be overloaded, may subsequently break and allow the pile to fall. This is a severe hazard to **ALL** site personnel and must be avoided at **ALL** times.

- Insert the lifting chain correctly (without twists or knots etc.) and secure with the chain clamp, ensuring that the chain clamp is a minimum of 6 links up from the bottom of the chain.
- Clear all personnel standing in the working area and lift up the pile until it hangs freely off the ground.
- Lower the pile so it can be correctly inserted into the clamp. Once firmly inserted close the jaws. Ensure lifting chain is not snagged in EMV. **NOTE:** the hard jaw footprint must be fully over the pile face and the pile face itself should not be visually deformed or have material such as weld protrusions where the hard jaw contacts.
- Manoeuvre the pile to its insertion point and push the pile slowly into the ground. Plumb the pile and Ensure that **ALL** personnel are out of the working area.
- Start the vibrator and adjust (crowd) the hydraulic rams so that the vibrator is level and always sits directly on top of the pile as it goes into the ground.
- When the pile has reached the required depth turn the vibrator off. Release the hard jaws from the pile and remove the lifting chain.
- Repeat the above stages to continue.

The customer may want to consider the use of piling guides to aid piling operations.

5.3 Removing Piles

- Ensure that all safety points and maintenance have been carried out before starting the excavator, see Section 7 for details.
- Check that it is safe to remove the dipper arm. Release the stand from the jaws of the vibrator. Manoeuvre the vibrator above the pile so that there is sufficient lifting chain to go through the hole at the top of the pile (no less than 6links).

WARNING: Allow enough free chain length for the pile to rotate to vertical during the lifting process without jamming against the underside of the Clamp Body. If this happens the chain will be overloaded, may subsequently break and allow the pile to fall. This is a severe hazard to **ALL** site personnel and must be avoided at **ALL** times.

- Insert the lifting chain correctly (without twists or knots) and secure with the chain clamp. **Under NO CIRCUMSTANCES should a pile be pulled using the Lifting Chain only, the Lifting Chain is designed to carry the self-weight of the pile only.**
- Clamp the vibrator onto the pile head ensuring that it is level. **Ensure that ALL personnel are out of the working area. NOTE:** The hard jaw footprint must be fully over the pile face and the pile face itself should not be visually deformed or have material such as weld protrusions where the hard jaw contacts.
- Ensure the excavator is set upon level ground.
- Start the vibrator and allow the soil to loosen around the pile. Start to lift up the pile, ensuring verticality and ensure that the pile clutches are not rubbing together. Pay attention to the distortion of the rubber sandwich mounts (see figure 7.1 in Section 7 for details) - **Under NO CIRCUMSTANCES should the distortion exceed 30mm.**
- After removing the pile, turn the vibrator off, (if a build up of soil/clay has occurred on the pile surface safely remove the debris with the vibrator **turned off** and the pile securely supported or laying flat). Move the pile to a suitable area and place it on the ground. **Ensure that ALL personnel are out of the working area while the pile is being extracted or moved.**
- Hold the pile on the ground and release the jaws. Raise the vibrator off the pile slowly, ensuring that there is no snatch on the lifting chain. Slowly lower the pile towards the ground. Remove the lifting chain (**DO NOT** drag the pile with the Lifting Chain).
- Repeat the above stages to continue.

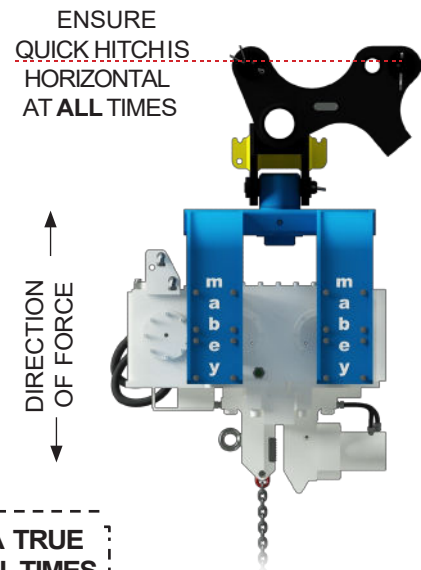

UNDER **NO** CIRCUMSTANCES MUST THE QUICKHITCH CLASH WITH THE ADAPTOR BRACKET 'NECKING' **MUST** BE AVOIDED

IMPORTANT NOTE: WHEN REMOVING PILES A TRUE VERTICAL EXTRACTION MUST BE USED AT ALL TIMES

5.4 Piling Refusal and Rebound

As with all machinery, there is a limit to the operational conditions under which the machinery is expected to operate. For vibratory driving, The Shoring Technology Interest Group {STIG} defines these limit conditions for **REFUSAL** and **REBOUND** as:

REFUSAL - under normal conditions, refusal is defined when the time taken to drive a pile 250mm, exceeds 5 minutes. The penetration distance of 250mm is absolute, i.e. No conversion is allowed, for instance, 20 minutes for 1m penetration.

REBOUND - This occurs when a large proportion of the EMVs energy is reflected up through the pile as a result of hitting an impenetrable layer or obstruction. The reflected forces will be transferred back into the EMV and the suppressor head and as a result, the head will start "jumping" relative to the vibratory case.

In this situation driving should be stopped **IMMEDIATELY**.

6.0 Basic Maintenance

6.1 Preliminaries

The Excavator Mounted Vibrators have been designed to give years of trouble-free service. Providing the equipment is treated with respect and the basic maintenance procedures are adhered to there will be little additional work required. Visual inspection of the EMV by a competent person on a daily basis and before being taken into service can prevent many potential problems from occurring. Ensure that lifting accessory test certificates are correct and valid at all times.

- All service and maintenance work **MUST** be carried out by Mabey Hire Ltd Pty. only.
- Daily checking of the machinery should be carried out by a competent person that has had demonstrations/ advice from a Mabey Hire Ltd Pty. representative.
- The equipment should be inspected at ground level only and should be positioned so as to be stable at all times.
- Secure the equipment against unexpected starting during the daily maintenance process.

Figure 7.1 (see Section 7.2 and Appendix B for details)

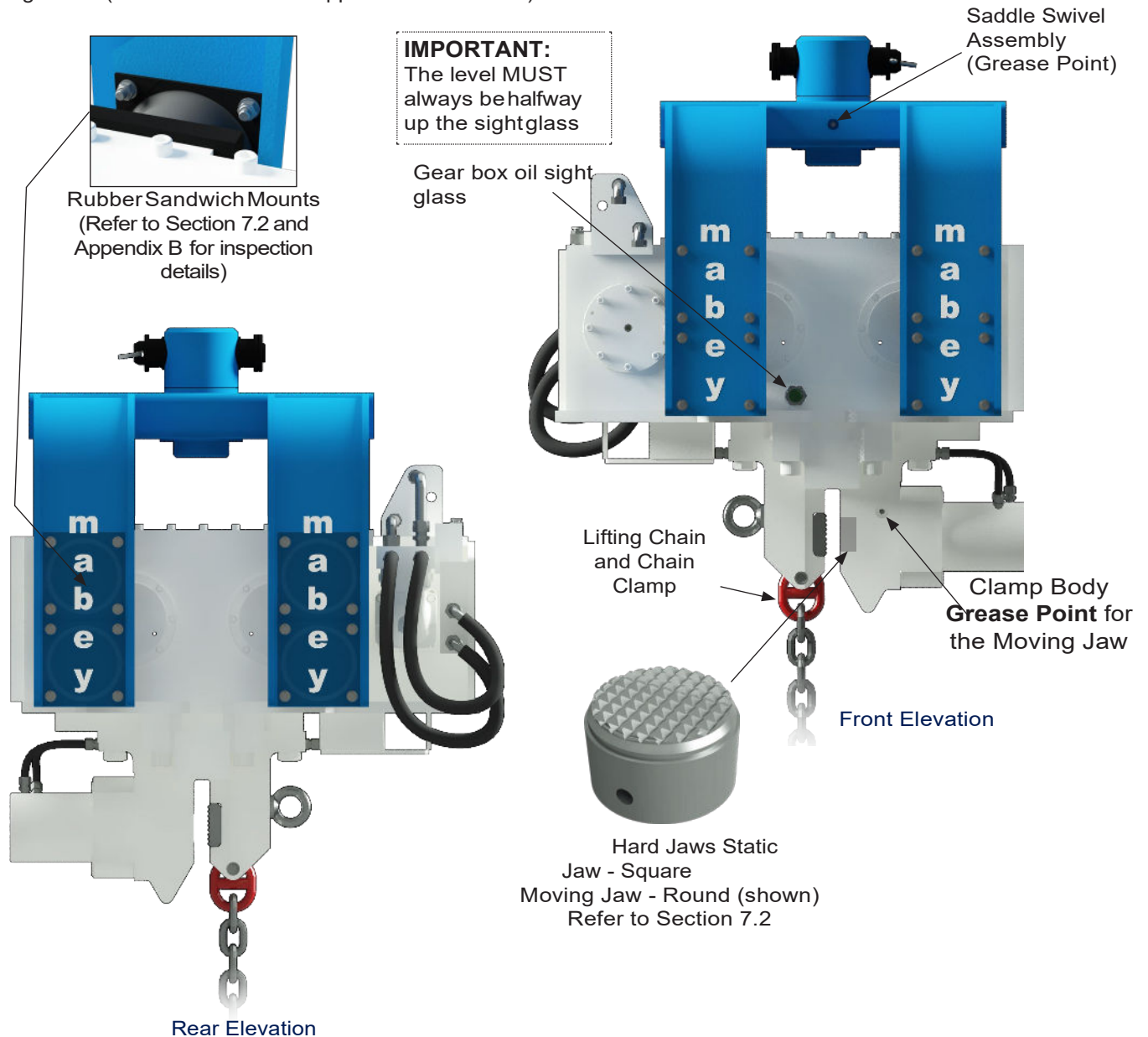

6.2- Daily Maintenance / Checks

NOTES:

- Refer to Fig.7.1 on the previous page and Appendix B for additional details.
- All personnel that are to be carrying out the daily checks are to have had demonstrations / advice from a Mabey Hire Ltd Pty. representative.
- Please contact Mabey Piling Attachment Services on 07 3803 8725, hydraulics@mabey.com.au for more details.

Daily Maintenance /Check Criteria

- Grease the two grease points on the EMV - one on the Saddle Swivel and the other on the side of the Clamp Body. Two or three pumps with a molybdenum-based grease will be adequate, (see figure 7 for details).
- Check visible screws, bolts, fittings etc for tightness.
- Visually inspect all hydraulic hoses and fittings for leaks or damage.
- Check the gear oil level in the vibrator. The level must be halfway up the sight glass.
- Inspect the lifting chain and chain clamp for damage. The chain should be in good order, free from any structural damage or permanent deformation of any kind. The chain clamp should also be free from any structural damage and its correct operation and safe function should be checked by depressing and releasing several times - any binding or hesitancy with its operation should result in it being changed for a new certified item. The chains coupler and anchorage point should be in good order showing no signs of damage, wear or cracking. **Remember, if in doubt, contact Mabey Hire Ltd Pty.**
- Inspect the condition of the Hard Jaws: When new, the teeth on these pads have some flats (approx. 1.5mm x 1.5mm). Over time they will wear down and flatten out more and may even become chipped. If not changed when required, they may lose their grip on a pile during driving and certainly during extraction. Besides causing a reduction in performance, this can become a safety hazard. The limit of wear is as follows:
 - The flats at the top of the teeth should be **no more** than 5mm x 5mm, (this equates to a depth from top of the teeth to the base of the pad of 2mm).
 - There are 81 teeth on the square static jaw pad - **no more** than 16 (20%) may be damaged or unevenly worn beyond the above criteria.
 - There are 57 teeth on the round moving jaw pad - **no more** than 11 (20%) may be damaged or unevenly worn beyond the above criteria.
 - Each type of Jaw has a cut notch into the perimeter teeth in order to aid in the inspection.

Wear line indicators
(cut notch)



Static Jaw

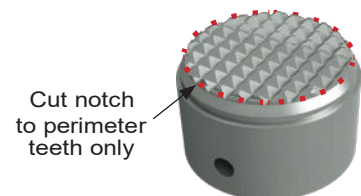
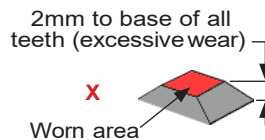
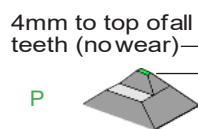

Moving Jaw

- Inspect the rubber Sandwich Mounts (Elastomers) for wear or damage. Wear is typified by splitting/tears. This usually occurs in the rubber adjacent to the bonded steel plates and is usually a result of fatigue in the material over a long period of time. Cracking/softening may occur but this is usually associated with long term exposure to sunlight or exposure to petroleum based products. As a general rule change the Sandwich Mount if any single tear or split exceeds 40mm or if the rubber has become contaminated.
- Check the overall condition of the Swivel Assembly. Check that the Lifting Bolt and Nut (that are the centre piece of this assembly) only allow rotational movement with minimal axial movement. Excessive axial movement will allow the assembly to rattle around, make more noise and cause in turn more wear. If the axial play exceeds 1 mm then **DO NOT USE** - contact Mabey Hire Ltd. immediately.
- Check the condition of the Boom Adaptor Bracket, Shear Pins, Spacers and Bushes. The whole assembly should be relatively tight with minimal play in the components. The bracket needs to be able to float a little from side to side - as much as 5/10 mm is acceptable. The pins and bushes should however be little more than a running fit - clearances of more than 0.5mm would be considered excessive.

7.0 Important Points

IMPORTANT NOTE: Failure to observe the following points could result in serious bodily injury.

7.1 Basic Safety Points

- The vibrator should only be operated by suitably qualified personnel.
- There should be visual contact between operator and slinger (spotter) at all times.
- Monitor the piling operation constantly - interrupt the process immediately if any danger occurs.
- **DO NOT** operate the vibrator if **ANY** person is within a 15m radius of the unit.
- Consider machine stability at all times.
- The operator should inspect the equipment for defects every day and before being taken into service. Any defects that affect operational safety should be corrected before the equipment is taken into service - see Section 7.
- Pay attention to the Safe Working Load of all lifting accessories at all times.
- The working area should be properly illuminated.
- Work safely at all times and within the requirements of all local legislation.
- The vibrator can become very hot during operation - Do **NOT** touch it unless wearing appropriate protective clothing.
- The maximum weight of pile that can be used with the EMV-300 = 800kg & with the EMV-450 = 1000kg & with the ABI HVR-60= 1500 kg

7.2 Responsibility

Those who are in charge of, or responsible for, the use and maintenance must ensure that the vibrator and all its auxiliary equipment are in good condition.

Piling should only be carried out under the supervision of an appropriately qualified and experienced person who can assess that the work is carried out safely.

The excavator operator must ensure that their communication signals are understood, by those on the ground, and followed. During piling operations, the excavator operator must watch out for any potential hazards.

Working Conditions

Vibrators should only be operated and driven on firm ground with clear visibility of the working area and the process monitored constantly.

The vibrator stand must stay upright and horizontal (at all times) to avoid personnel injury. Do **NOT** operate the vibrator if **ANY** personnel are within a 15m radius of unit. Personnel are at risk when within this area from:

- Falling piles - should the pile be handled incorrectly
- Liquids under high pressure and associated components
- Mechanical failures of equipment components
- Noise - wear ear protection equipment when inside this area
- Unexpected overturning of the excavator

Working near Underground Obstacles

Before the start of any piling work it is the customer's responsibility to find out if there are any underground obstacles within the working area which could be dangerous to personnel. In the case of unforeseeable contact or damage of an underground obstacle, work must stop immediately and the person in charge informed.

8.0 General

Since our policy is one of continual improvement, components may vary in detail from the descriptions given in this publication.

Appendix A -Warnings

It is highly recommended that the operator keeps this Appendix in clear view while using the EMV. A1 -

Vertical Alignment

IMPORTANT NOTE: WHEN INSTALLING AND REMOVING PILES, A TRUE **VERTICAL** INSTALLATION AND EXTRACTION **MUST** BE USED AT **ALL** TIMES.

WARNING: DO NOT install or extract piles that are not vertical or if the EMV is not truly vertical.

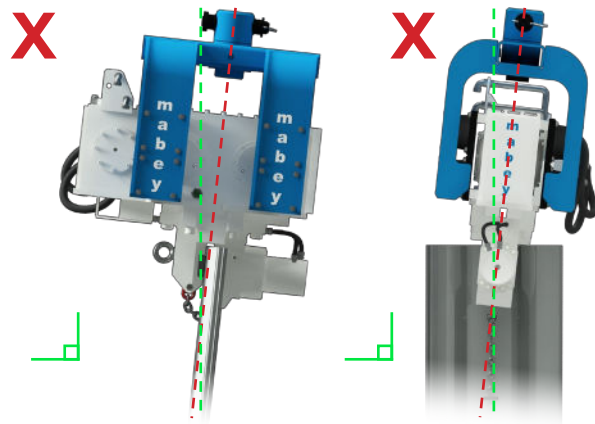

A2 - Horizontal Alignment

WARNING: DO NOT use the EMV if the Quick Hitch is not horizontal.

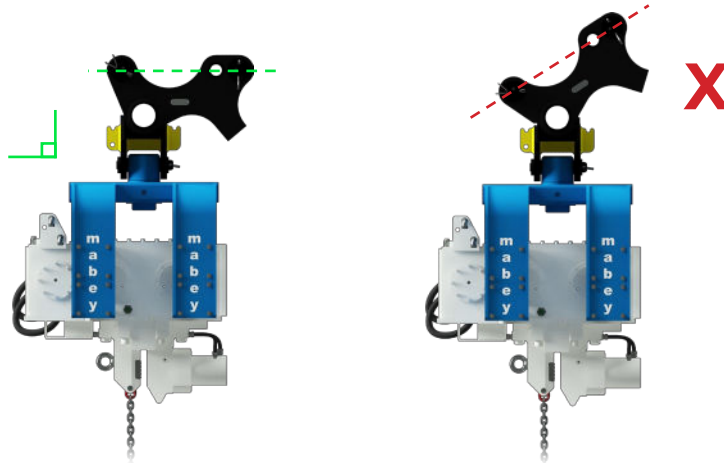

A3 - Lifting Chain and Chain Clamp

WARNING: Allow enough free chain length for the pile to rotate to vertical during the lifting process without jamming against the underside of the Clamp Body. If this happens the chain will be overloaded, may subsequently break and allow the pile to fall. This is a severe hazard to **ALL** site personnel and must be avoided at **ALL** times.

Advised length 390mm.

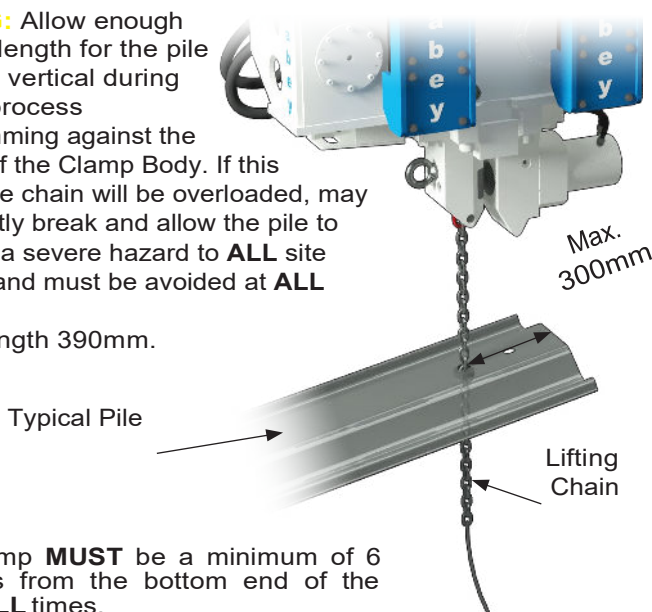

Chain Clamp **MUST** be a minimum of 6 chain links from the bottom end of the chain at **ALL** times.

A4 - Greasing Pins



NOTE: Ensure the Pin between the Quick Hitch Bracket and Universal Bracket is greased daily, (see sticker on the EMV and picture above for details).

Appendix B - Proof of Inspection Form

NOTE: The inspection of this product and completion of this form must only be carried out by persons trained and authorised to do so.

IF ANY DAMAGE IS FOUND, CONTACT MABEY HIRE LTD PTY.. PILING ATTACHMENT SERVICES ON 07 3803 8725 OR HYDRAULICS@MABEY.COM.AU AND REMOVE THE EMV FROM USE.

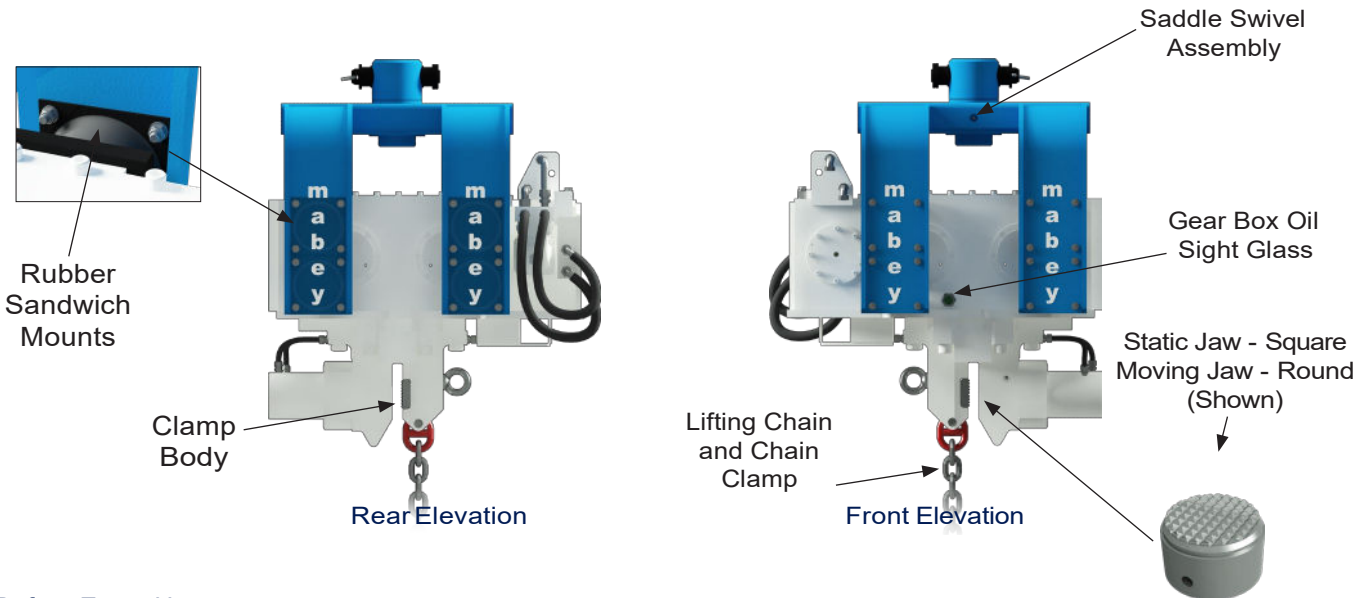

Before Every Use

Procedure	Details	Checked
Visually inspect the Clamp Body and mechanism before every lift and keep free from debris		
Check ALL visible screws, bolts, fittings etc. for tightness	-	
Check there are no missing screws, bolts or fittings on the Assembly	-	
Check Quick Hitch bracket (Standard Bracket if used) and Pins for defects and damage, ensure that the split pins are not worn through (if in doubt, change the split pin)	Refer to Section 4 for Component Identification	
Grease the two grease points on the Swivel and Clamp body. Two or three pumps with a molybdenum-based grease will be adequate		

Appendix B - Proof of Inspection Form Continued

Before Every Use Continued

Procedure	Details	Checked
Grease the Pin connecting the Standard Bracket and Standard Quick Hitch Bracket daily	<p>Standard Quick Hitch Bracket (EMV-D-QHB) Connecting Pin Standard Bracket (EMV-D-SB)</p> <p>NOTE: Pin MUST be greased daily</p>	
Visually inspect all hydraulic hoses and fittings for leaks or damage and ensure all hoses are tight		
Check the gear oil level NOTE: The level must always remain halfway up the sight glass	<p>Gear Box Oil Sight Glass</p>	
Check the Rubber Sandwich Mounts for tears or missing bolts NOTE: As a general rule change the Sandwich Mount if any single tear or split exceeds 40mm or if the rubber has become contaminated	<p>Rubber Sandwich Mounts</p>	
Check the Swivel Assembly for damage and that it only allows rotational movement and minimum axial movement. Axial movement should not exceed 1 mm	<p>1mm Max Saddle Swivel Assembly</p>	
Check Static and Moving Jaws for excessive wear on ALL teeth and general damage. Note: each type of Jaw has a cut notch into the perimeter teeth in order to aid inspection. No more than 16 teeth (20%) on the Square Static Jaw may be damaged or unevenly worn below the Wear Line Indicators No more than 11 teeth (20%) on the Round Moving Jaw may be damaged or unevenly worn below the Wear Line Indicators	<p>4mm to top of all teeth (no wear)</p> <p>Worn area</p> <p>Wear line indicators (Notch cut around perimeter)</p> <p>2mm to teeth (excessive wear)</p>	
Inspect the Lifting Chain assembly for wear, damage and bent links. Also inspect the anchorage point and coupler for any damage. NOTE: Also inspect the Lifting Chain between lifts	<p>Damaged Link</p>	
Check the Chain Clamp for damage and safe function. WARNING: Allow enough free chain length for the pile to rotate to vertical during the lifting process without jamming against the underside of the Clamp Body. If this happens the chain will be overloaded, may subsequently break and allow the pile to fall. This is a severe hazard to ALL site personnel and must be avoided at ALL times	<p>Advised Length = 390mm</p> <p>6no Chain Links Minimum</p> <p>Lifting Chain</p> <p>Chain Clamp</p>	

IMPORTANT CHAIN CLAMP NOTE: When performing equipment checks, the end user should always remain conscious of adverse weather and environmental factors particularly if temperatures are approaching zero degrees Celsius. Equipment with moving parts should, as far as is reasonably practicable, be kept dry and well lubricated to ensure minimal water/frost ingress. If equipment is subjected to freezing temperatures, an additional check should be made to identify any “frozen” components. Tell-tale signs include condensation, frozen water droplets and frost covered surfaces - in such cases, extra care should be taken to ensure that all moving parts are able to move freely.

IF IN DOUBT, CONTACT MABEY HIRE LTD PTY. PILING ATTACHMENT SERVICES ON 07 3803 8725, hydraulics@mabey.com.au



Appendix B - Proof of Inspection Form Continue

Confirmation of Inspection			EMV No:	
			Inspected by:	
Day	Date	Comments	Name	Signature
1	/ /			
2	/ /			
3	/ /			
4	/ /			
5	/ /			
6	/ /			
7	/ /			
8	/ /			
9	/ /			
10	/ /			
11	/ /			
12	/ /			
13	/ /			
14	/ /			
15	/ /			
16	/ /			
17	/ /			
18	/ /			
19	/ /			
20	/ /			
21	/ /			
22	/ /			
23	/ /			
24	/ /			
25	/ /			
26	/ /			
27	/ /			
28	/ /			
29	/ /			
30	/ /			
After 30 Days of use, Contact Mabey Hire Ltd. to Inspect				

IF IN DOUBT, CONTACT MABEY HIRE LTD PTY. PILING ATTACHMENT SERVICES ON 07 3803 8725, hydraulics@mabey.com.au



Appendix C - Provision of a Mabey Hire Ltd Pty. Site Fitter

Mabey Hire Ltd Pty. Site Fitters are offered subject to the following terms and conditions. Please contact the Piling Attachment Services on 07 3803 8725, hydraulics@mabey.com.au for more details. Prior to the Mabey Hire Ltd Site fitters' arrival on site it is the Customer's responsibility for:

C1. Responsibility for the Safe System of Work

C1.1 The customer must ensure that all piling operations are carried out under the supervision of an appropriately qualified and competent person (this includes the fitting and removal of piling attachments to the excavator).

C1.2 The customer is responsible for the risk assessment and Safe System of Work (RAMS) for the work to be carried out. The risk assessment should address such items as safe working area (away from the excavation) and access requirements for a light van and trailer. A safe system of work should be based on the control measures identified in the risk assessment.

C1.3 Provide a site induction for our Fitter.

C1.4 The use, free of charge, of the site welfare facilities.

C2. Attachment of the Piling Accessory

C2.1 The piling accessory will be mounted on the excavator's dipper arm in place of the excavator's bucket. The excavator should be fitted with an industry standard double pin Quick Hitch device or pinned to the dipper arm if no quick hitch fitted or deemed unsuitable.

C2.2 The hydraulic motor on the piling accessory is driven by connecting the two motor hoses to either side of the bucket ram circuit, or to any other suitable auxiliary circuit. [Specific to EMV hammers, there is a drain line which must be fed directly into the hydraulic tank in the excavator or connected to the breaker circuit return line].

NOTE: IT IS IMPERATIVE THAT THE DRAIN LINE IS NOT RESTRICTED AS THIS WILL CAUSE A BUILD UP OF PRESSURE WHICH WILL BLOW THE MOTOR. THE MOTOR IS FITTED WITH A BLOW OFF VALVE. WHEN OIL IS ESCAPING FROM THIS VALVE ALL OPERATIONS MUST BE STOPPED AND MABEY HIRE LTD. INFORMED IMMEDIATELY.

C3. Operating Conditions

C3.1 It is imperative that the piling accessory is only attached/removed and operated with the excavator standing on firm ground with clear visibility of the working area. On removal from the excavator, the accessory should be placed in its correct stand/stillage.

C3.2 The equipment is hired under Mabey Hire Ltd Pty. terms and conditions and as such any theft, damage caused by misuse or abuse will be charged accordingly.

C4. Trained and Competent Personnel

C4.1 The excavator operator must be appropriately trained (this is normally to CPCS standards) and should be suitably experienced and issued with the appropriate PPE. Our fitter has the authority to check the relevant operator competency card before they commence fitting the accessory.

C5. Suitable Excavator for the Work

C5.1 The excavator type (make and model) and the type of Quick hitch, the pin sizes and spacing must be notified to Mabey Hire Ltd before the accessory is hired to ensure compatibility and efficient operation.

C5.2 The excavator should be in good condition and have the relevant certification for carrying out the works.

C6. The Mabey Hire Ltd. Site Fitter Will:

C6.1 Provide a Risk Assessment and Safe System of work for the type of work the fitter expects to carry out.

C6.2 Provide a user guide for the piling accessory.

C6.3 When on site, check that the safe system of work is suitable to allow the work to be carried out in a safe manner.

C6.4 Advise the operator of the correct attachment and removal of the accessory.

C6.5 Advise the operator of the correct operation of the attachment including the potential dangers and warnings stated in the user guide.

C6.6 Explain the daily inspection and maintenance regime.

C6.7 Issue a handover document once the unit has been fitted and demonstrated to the operator.

C7. The Mabey Hire Ltd. Site Fitter Will NOT:

C7.1 Organise the workforce.

C7.2 Operate the excavator (even if certified unless written authorisation from customer AND Mabey Hire Ltd Pty).

C7.3 Carry out training.

C7.4 Assess the competence of the operator.

C7.5 Provide tools, unless they are strictly specialist tools that are not obtainable from anywhere else and have been agreed during contract negotiations.

HIRE CHECKLIST

EMV 300 / 450 / ABI / GRIZZLY SIDE GRIP



Customer Questions

Has a geotechnical report being completed?	
Is the EMV correct size for the excavator being used?	
Which type of sheet pile profile and length is being used for the job?	
Does the client need an engineering report done?	
Is there a case drain line present?	

Hitch Selection for customer Excavator – Refer to diagram below

Pin diameter (A)	mm
Pin center to center (B)	mm
Hitch width (gap) (C)	mm

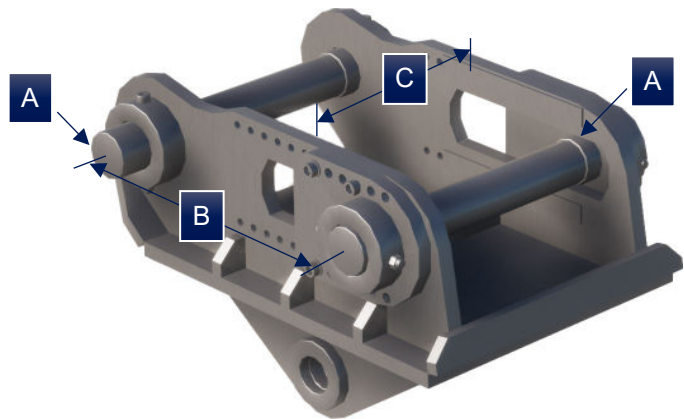

Excavator flow- pressure requirements

Type	REQ. FLOW (Liters per min)	ACTUAL FLOW	REQ. PRESSURE (bar) (MIN) (MAX)		ACTUAL PRESSURE
EMV300	130		280	350	
EMV450	195		280	350	
ABI HRV60	195		280	350	
GRIZZLY MG60	200		310	330	
	Case drain pressure		0	5	

Additional Equipment

Are extension hoses required? Is a gooseneck used?	
Does a case drain hose kit need to be supplied?	
What type of customer excavator hydraulic fitting are used?	Type of fitting (bsp/ npt/ jic)

Customer Signoff

Name:

Signature:



While information in this Guide is correct at time of printing, product specifications and product availability are subject to change without further notice. Please visit our website for the most up to date information. Job site photos are strictly intended for general product illustration only and may not comply with all applicable safety standards or site requirements. Specification data has been taken from manufacturers' serialised specific tabulated data.

1800 622 394

www.mabey.com/au

