

# Sheet Piling, Hydraulic Bracing Systems and Engineering Project Services

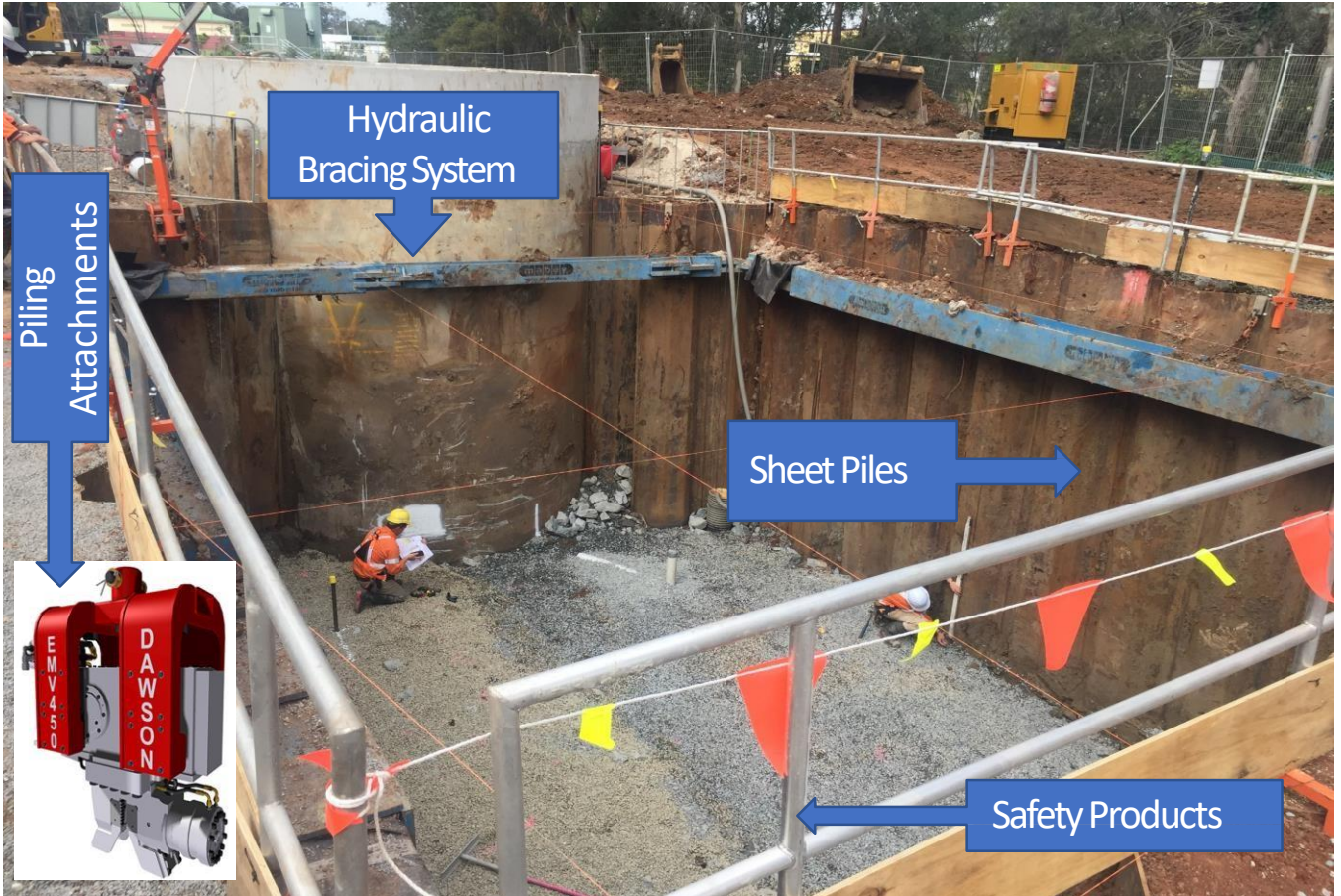

## CONTENTS:

	Page(s)
Sheet Piles and Trench Sheets	1 - 2
Piling Attachments – General	3
Piling Attachments – EMV's In Detail	4 – 7
Hydraulic Bracing Systems	8 - 15
Safety Products	16
Engineering and Project Service	17 – 18
Locations	19

# Sheet Piles And Trench Sheets

## What are Mabey Sheet Piles and Trench Sheets?

Mabey Sheet Piles and Trench Sheets are thin steel members that are driven into the ground to provide earth retention and excavation support. Sheet Piles can also be used in river and coastal applications with corner piles to help reduced the amount of inflow into a cofferdam.

**Sheet Piles** are strong and heavy and have interlocking edges which allows the sheets to clutch together to create a continuous wall.

**Trench Sheets** are light, easy to handle and have an overlapping connection which do not clutch together to create a lapping wall.

Both sheet types can be used for Temporary Works and Permanent Works Applications.

Both sheet types are available for **hire** and for **sale**.



# Sheet Piles And Trench Sheets

## Product Specifications

**Table 1**

Profile	Steel Grade	W (mm)	H (mm)	tf (mm)	tw (mm)	Weight (kg/m)	Weight (kg/m <sup>2</sup> )	Moment of Inertia (cm <sup>4</sup> /m)	Section Modulus (cm <sup>3</sup> /m)	Moment Capacity (WLL) - FOS of 1.5
M12	HA350	550	87.5	6	6	32	58.2	796	182	42.5
GU7S	S355	600	311	7.2	6.9	46.3	77	11540	740	175
L603	S355	600	320	9.6	8.2	64.8	108	18600	1200	284
SPU-3W	S355	600	360	13.4	13.4	81.6	136	32400	1800	426
NS-SP-10H	S355	900	230	10.8	10.8	86.4	96	10500	902	213

### PROFILE

### TYPICAL USES

#### Overlapping Trench Sheet – 550mm (W)

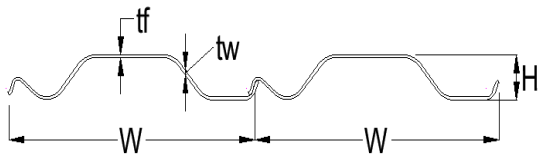

Available in Lengths of 4m to 6m\*

- Trench and Manhole Construction
- Utilities Construction
- Working in and around Services
- Shallow single sided cantilever walls
- Shallow to Medium Cofferdams

#### Interlocking Sheet Pile – 600mm (W)

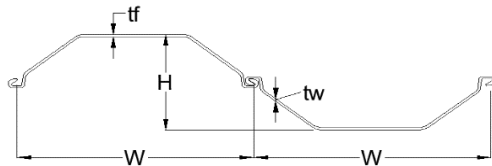

Available in Lengths of 6m & 12m

- All above
- Medium single sided cantilever walls
- Deep Cofferdams
- Working in and near Rivers and coastal applications.
- Basements

#### Interlocking Sheet Pile – 900mm (W)

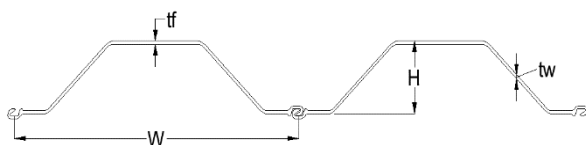

Available in Lengths of 6m

Note: Other sheet lengths are available upon request.



# Piling Attachments - General

## What are Mabey Piling Attachments?

Mabey Piling Attachments are the additional equipment required to safely **install** and **extract** sheet piles and trench sheets.

Mabey offer the below range of piling attachments:

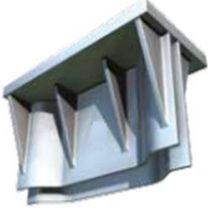
## Product Specifications

PRODUCT	DESCRIPTION
<p data-bbox="111 544 472 582">Ratchet Release Shackle</p>  <p data-bbox="382 673 576 835">5T WLL (V) 2.5T WLL (H) 15kg</p> <p data-bbox="619 627 696 855">PITCHING</p>	<ul data-bbox="743 540 1353 934" style="list-style-type: none"><li>• Generally Suited for <b>lifting single Trench Sheets into position</b>. Once sheets have been lifted into hole and are stable, the ratchet can be safely removed by turning the ratchet at ground level via rope.</li><li>• Improves Sheet Install Safety</li><li>• Can also be used for lifting Columns, Pipe Piles, Sheet Piles etc.</li></ul>
<p data-bbox="111 975 425 1013">M12 Sheet Drive Cap</p>  <p data-bbox="396 1087 472 1125">29kg</p> <p data-bbox="619 990 696 1197">INSTALL</p>	<ul data-bbox="743 980 1329 1218" style="list-style-type: none"><li>• Generally Suited To Pushing <b>3m To 8m long M12 Trench Sheets</b> Into Loose to Medium Ground.</li><li>• Improves Trench Sheet Driveability</li><li>• Reduces Damage to Trench Sheets</li></ul>
<p data-bbox="111 1265 522 1303">M12 Sheet Extractor Clamp</p>  <p data-bbox="386 1390 548 1489">7T WLL (V) 12kg</p> <p data-bbox="619 1290 696 1560">EXTRACT</p>	<ul data-bbox="743 1297 1315 1549" style="list-style-type: none"><li>• Generally Suited For <b>Removing Various Lightweight Trench Sheets</b>.</li><li>• Can Be Used To Remove Sheet Piles If Pitching Holes Are Suitably Located.</li></ul>
<p data-bbox="111 1607 636 1645">Excavator Mounted Vibrator (EMV)</p>  <p data-bbox="562 1711 696 1960">INSTALL &amp; EXTRACT</p>	<ul data-bbox="743 1612 1322 2047" style="list-style-type: none"><li>• Generally Suited To <b>Driving Sheet Piles and Trench Sheets up to 7m long</b> Into Very Loose To Dense Material. Will Struggle to drive In ground that is Firm + Clay Material without prior pre-drilling.</li><li>• EMV 300 Model Generally Suited To <b>12T To 35T</b> Excavators</li><li>• EMV 450 Modal Generally Suited To <b>25T To 45T</b> Excavators</li></ul>

# Piling Attachments – EMV's

## How EMV's work.

EMVs reduce the cohesion and friction of soils through vibrations which effectively fluidises the soil, making it easier and more cost efficient to install trench sheets and sheet piles. The weight of the piling hammer and the applied force are enough to drive the trench sheet/sheet pile to the required depth quickly, quietly and efficiently. The same applies when extracting and the required pulling force is minimized due to the reduced friction. EMV's work best in granular (sands and gravels) and they will still function in cohesive soils (clays) but piles will not penetrate as far. **Pre-drilling can be used in the 1<sup>st</sup> instance to increase driving efficiency.**



## Product Specifications

Table 2

DAWSON	EMV 300	EMV 450
Static Moment (kgm)	4.6	6.9
Frequency (rpm)	2400	2460
Centrifugal Force (kN)	300	453
Amplitude (mm)	14.7	13.7
Min Hydraulic Flow Rate (L/min)	130	195
Max Hydraulic Flow Rate (L/min)	250	350
Max Hydraulic Pressure (bar)	350	350
Min Hydraulic Power (kW)	60	88
Dynamic Mass (kg)	625	1008
Total Mass (kg)	965	1275
Max Pile Mass (kg)	800	1000
Max Push/Pull Force (kg)	15000	15000
Clamp Force (tonne)	36	54
Typical Excavator Weight (tonne)	12 to 25	25 to 45

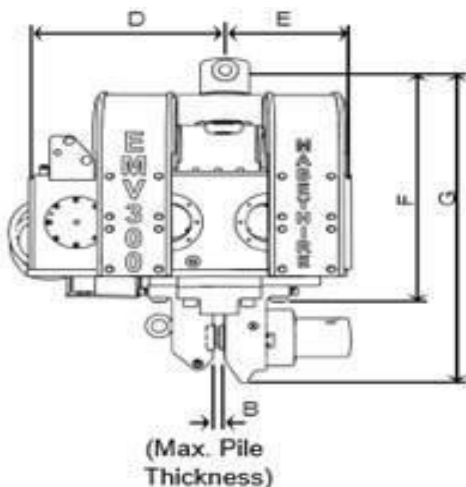

Dims (mm)	EMV Model	
	EMV 300	EMV 450
A	615	615
B	25	32
C	250	230
D	582	640
E	429	510
F	927	945
G	1200	1250
H	150	175

Image 1

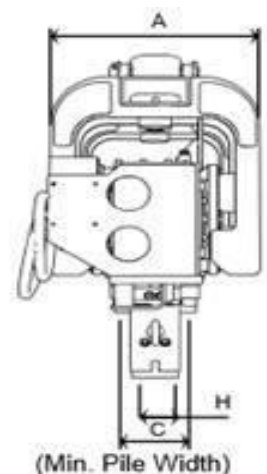

# Piling Attachments – EMV’s

## EMV Suitability Chart

The Chart below can be used to give an estimate on the EMV unit to use in given ground conditions. The chart below is a guide, not a guarantee!

**Chart 1**

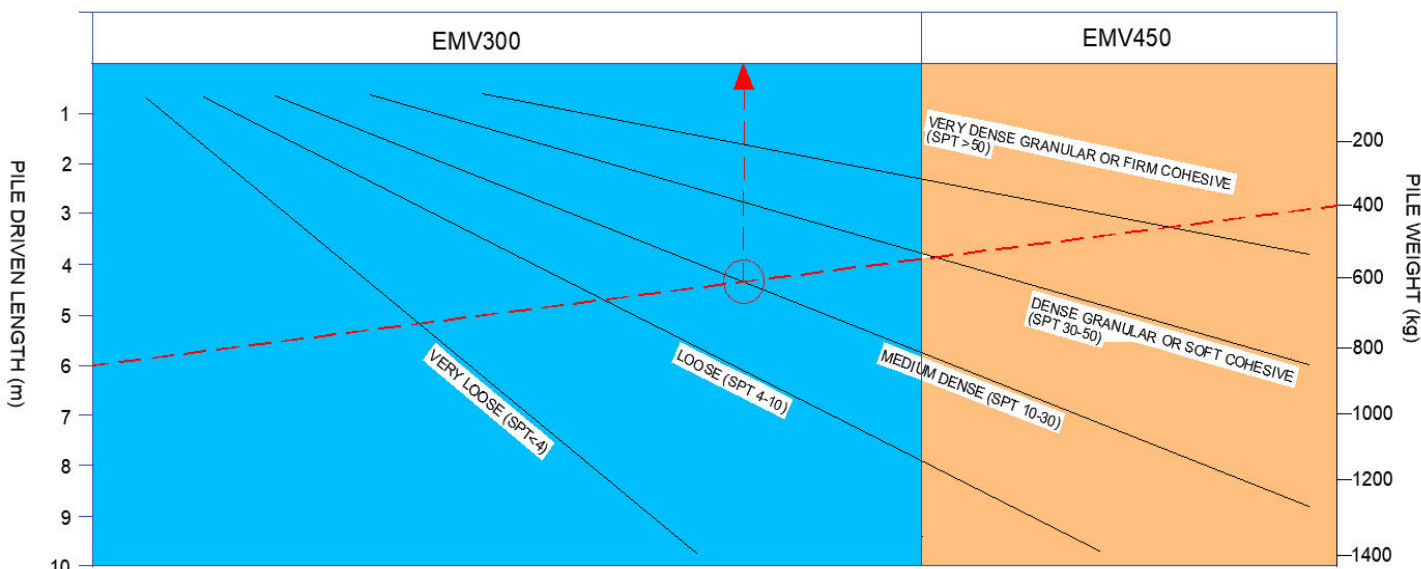

Example: For a 6m long 400kg sheet driven into Medium Dense Soil, an EMV 300 or larger is required (see dashed red line).

## Mabey Sheets Suitability Table for selecting appropriate EMV

The Table below has been put together based on the above EMV Suitability Chart.

The table below is a guide, not a guarantee!

**Table 3**

Mabey Sheet Profile	Ground Soil Profile				
	Very Loose (SPT < 4)	Loose (SPT 4-10)	Medium Dense (SPT 10-30)	Dense Granular or Soft Cohesive (SPT 30-50)	Very Dense Granular or Firm Cohesive (SPT > 50)
<b>EMV300</b> ●					
<b>EMV450</b> ●					
4m - M12	●	●	●	●	●
5m - M12	●	●	●	●	●
6m - M12	●	●	●	●	●
6m - GU7	●	●	●	●	●
6m - L603	●	●	●	●	●
6m - SPU-3W	●	●	●	●	●
6m - NS-SP-10H	●	●	●	●	●

Note: Sheets up to 6m long are only included in the above table due to lifting height restrictions on specific excavators. Pre-drilling can be used in the 1<sup>st</sup> instance to increase driving efficiency.

# Piling Attachments – EMV's

## EMV Vibration – Peak Particle Velocity (PPV) (mm/s)

Vibration occurs from all piling operations and varies from site to site. From extensive field testing our suppliers have provided information on how to predict Peak Particle Velocity in the ground at a given distance. Use Chart below to estimate PPV (mm/s) for specific EMV's.

**Chart 2**

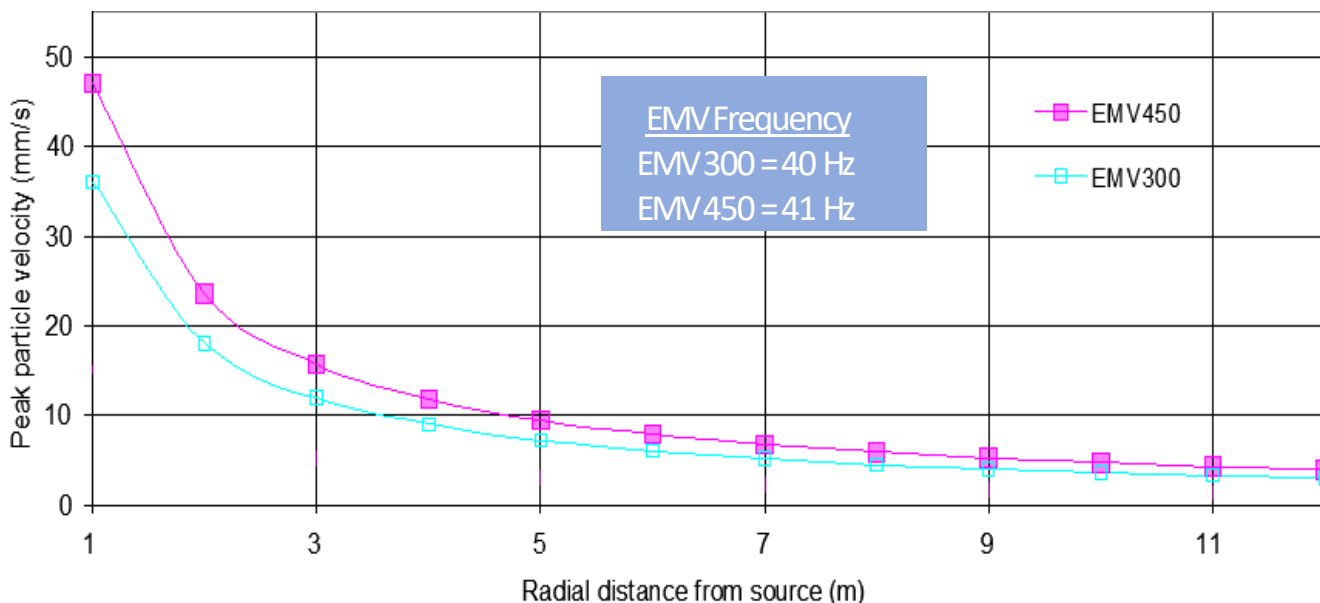

### EMV - Maximum Predicted vibration from piling operations - from BS5228

## Mabey EMV 300 and 450 PPV (mm/s) from Radial Source

The Table below has been put together based on the above EMV PPV Chart.

**Table 4**

EMV Model		Distance From Radial Source (m)										
		1	2	3	4	5	6	7	8	9	10	11
EMV 300	PPV (mm/s)	36.1	18.0	12.0	9.0	7.2	6.0	5.2	4.5	4.0	3.6	3.3
EMV 450		47.1	23.6	15.7	11.8	9.4	7.9	6.7	5.9	5.2	4.7	4.3

## EMV Refusal

Under normal conditions, refusal is defined when the time taken to drive a pile 250mm exceeds 5 minutes. The penetration distance of 250mm is absolute, i.e. No conversion is allowed, for instance, 20 minutes for 1m penetration.

# Piling Attachments – EMV's

## Thinking of ordering an EMV?

If an EMV is what you need to complete your piling project, then follow the below chart to ensure your job goes smoothly:

1. Determine if pre-drilling is required prior to piling.
2. See Chart 1 – Page 4
3. See Table 3 – Page 4

**NOTE 1:**

The full weight of an EMV + Mabey attachments can weigh as much as 2T. The weight of pile is to then be added on.

The EMV + attachments will take up approx. 2m of the excavator lifting height. The length of the pile is to be then added on.

- See Chart 2 – Page 5
- See Table 4 – Page 5

Chart 3

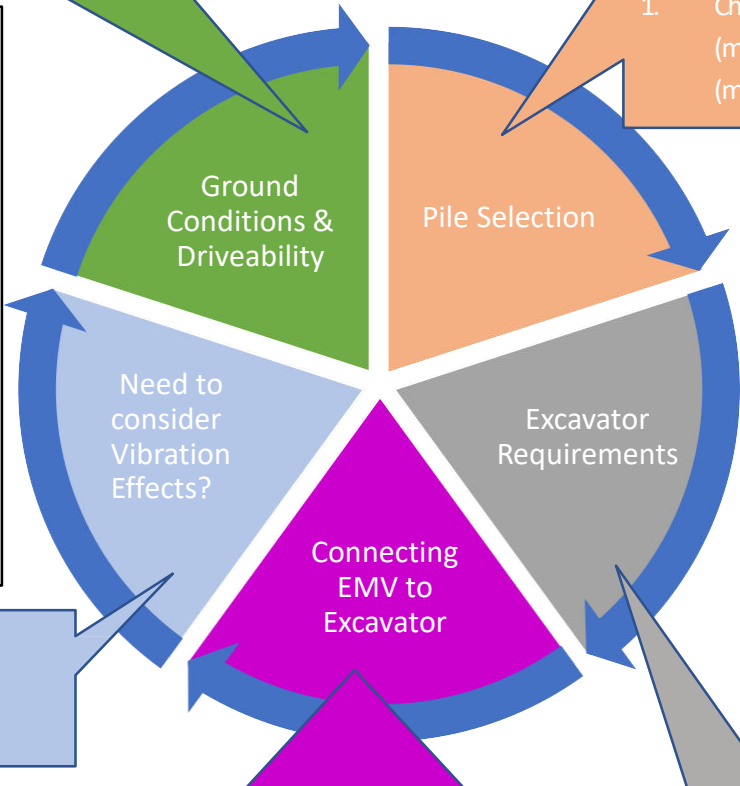

1. Are you driving in a straight sheet pile? If not seek further assistance.
2. Check Weight of pile is ok:  
(max 800kg for EMV300)  
(max 1000kg for EMV 450)
1. Check Thickness of pile is ok:  
(max 25mm for EMV300)  
(max 32mm for EMV450)

**NOTE 2:**

Auxiliary hydraulic circuit of excavator must have:

- Bi-directional flow capability
- hard lines
- screw on couplings & case drain
- All fitting must be Unrestricted

**THE DRAIN LINE MUST FLOW DIRECTLY TO TANK WITHOUT RESTRICTION.**

Physical Connection

Suggest using Mabey Fully Adjustable Quick Hitch which is suitable for 20-50T excavators. **Mabey require the following information:**

- Coupler pin centers (mm)
- Coupler pin sizes (mm)
- Distance between ears (mm)

Hydraulic Connection

There are 3 hoses that require attachment.

1. The Pressure line - connected to the bucket ram “extend” circuit.
2. The return line - connected to the bucket ram “retract” circuit.
3. The drain line - fed either directly back into the hydraulic tank on the excavator, or connected to the breaker circuit return line (must be unrestricted).

- Suggest that Enzed/Pirtek or alike visit site to undertake hydraulic connections. Further extension hoses may be required. See Note 2

1. Does your excavator have the required lifting height & lifting capacity? See Note 1
2. Is your excavator capable of running and maintaining the required operating specifications? See Table 2 – Page 4
3. Does your excavators hydraulic circuit suit? See Note 2



# Hydraulic Bracing Systems (HBS)

## What is a HBS

Hydraulic Bracing is a proprietary horizontal UC section with an extendable and retractable 1m hydraulic ram end unit. A HBS is traditionally used as an **internal support brace for supporting steel sheet piles and trench sheets** in a wide variety of shapes and sizes. A HBS can also be used as an internal support for permanent works structures such as basements and capping beams. A HBS requires no on-site welding.

## Typical 3D Image Layout

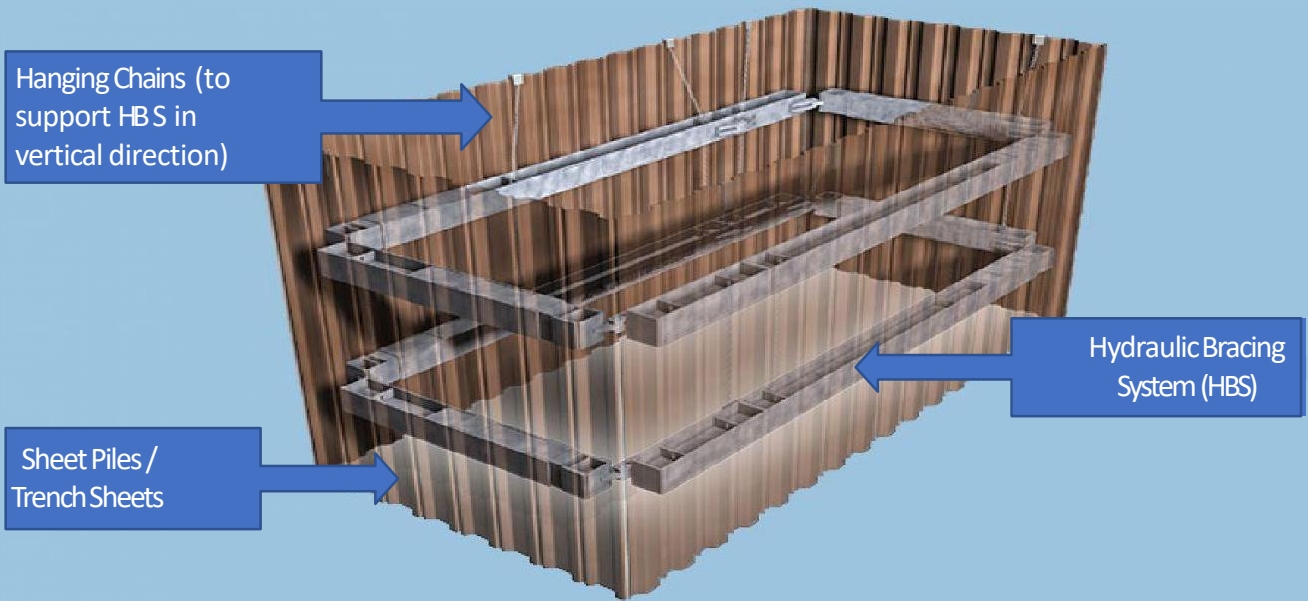

## 3D Image of main components

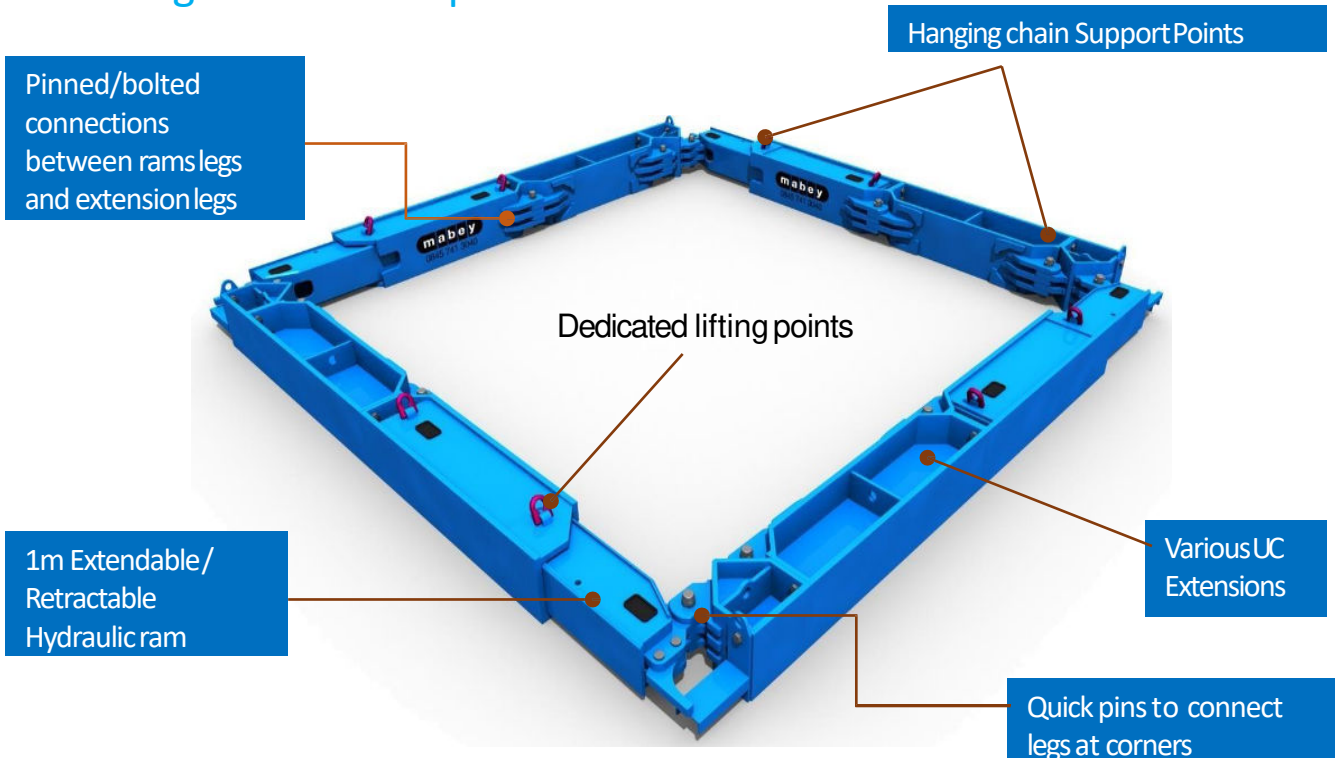



# Hydraulic Bracing Systems (HBS)

## Product Specifications

Mabey stock 2 types of Hydraulic Bracing Systems:

- Multibrace
- Supers Shaftbrace

Also available is the Mabey **Mechanical Bracing Strut (MBS)**. A MBS is a mechanical steel box section that connects to the Excavation Bracing System (EBS) to **increase the total frame span, and reduce frame deflection**. A MBS requires no on-site welding.

PRODUCT	DESCRIPTION
<p data-bbox="111 673 592 714">Multibrace (254 x 254 UC x 107)</p> 	<p data-bbox="749 673 1349 797">All Bracing Systems are flexible and can shore up many square, rectangular or irregular shaped holes.</p> <ul data-bbox="749 859 1363 1149" style="list-style-type: none"><li>• <b>Multibrace</b> is ideally suited for hole sizes of 2.8m to 10m square*.</li><li>• <b>Supershaft Brace</b> is ideally suited for hole sizes of 3m to 16m square*.</li><li>• <b>Mechanical Bracing Struts</b> can span up to a total length of 12m.</li></ul>
<p data-bbox="85 1129 664 1170">Super Shaftbrace (356 x 368 UC x 202)</p> 	<p data-bbox="813 1170 1306 1274">*Larger hole sizes are possible if Struts permit*</p> <p data-bbox="749 1284 1306 1326">Typical HBS shoring Applications are:</p>
<p data-bbox="114 1616 664 1709">Mechanical Bracing Strut (250 x 250 x 10tk SHS)</p> 	<ul data-bbox="749 1388 1349 1978" style="list-style-type: none"><li>• Fuel Tank</li><li>• Thrust and Reception Pits (Pipe Jacking)</li><li>• Underground Utility Structures e.g. Wet wells, GPT's, Valve Pits, Manholes, Electricity Boxes etc.</li><li>• Lift Pits</li><li>• Crane Bases</li><li>• Pile Caps</li><li>• Bridge Abutments</li><li>• Bridge Piers</li></ul>

## Multibrace Typical Build Up Components

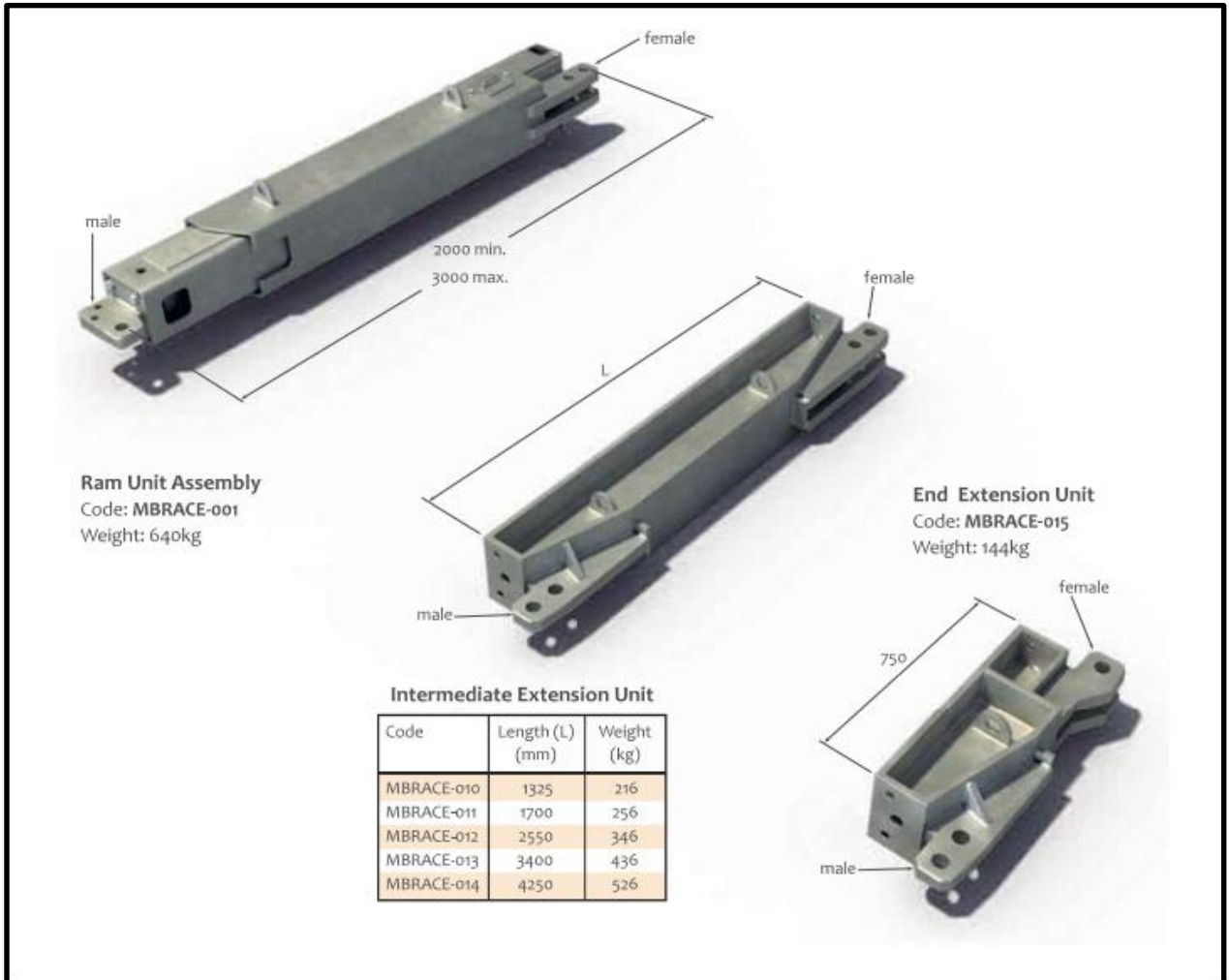

**Ram Unit Assembly**  
Code: MBRACE-001  
Weight: 640kg

**End Extension Unit**  
Code: MBRACE-015  
Weight: 144kg

**Intermediate Extension Unit**

Code	Length (L) (mm)	Weight (kg)
MBRACE-010	1325	216
MBRACE-011	1700	256
MBRACE-012	2550	346
MBRACE-013	3400	436
MBRACE-014	4250	526

Leg Arrangement	Leg Code	Clear Internal Dimensions (mm)				Corner Pin to Pin Dimension (mm)		Dimensions over Frame (Sheet to Sheet) (mm)		Leg Weight (kg)
		Between Walling Flanges		Between Walling Joints		min.	max.	min.	max.	
		min.	max.	min.	max.					
RAM	MBRACE-01	1923	2923	N/A	N/A	2000	3000	2523	3523	640
RAM 750	MBRACE-01A	2736	3736	2620	3620	2750	3750	3270	4270	784
RAM 1325	MBRACE-02	3311	4311	3195	4195	3325	4325	3845	4845	856
RAM 1700	MBRACE-03	3686	4686	3570	4570	3700	4700	4220	5220	896
RAM 2550	MBRACE-04	4536	5536	4420	5420	4550	5550	5070	6070	986
RAM 3400	MBRACE-05	5386	6386	5270	6270	5400	6400	5920	6920	1076
RAM 4250	MBRACE-06	6236	7236	6120	7120	6250	7250	6770	7770	1166
RAM 3400 1325	MBRACE-07	6711	7711	7045	8045	6725	7725	7245	8245	1292
RAM 4250 1325	MBRACE-08	7561	8561	7445	8445	7575	8575	8095	9095	1382
RAM 4250 1700	MBRACE-09	7936	8936	7820	8820	7950	8950	8470	9470	1422
RAM 4250 2550	MBRACE-10	8786	9786	8670	9670	8800	9800	9320	10320	1512

Note that sheet to sheet and clear internal dimensions include no allowance for deflection under load

## Safe Working Load Charts For Multibrace

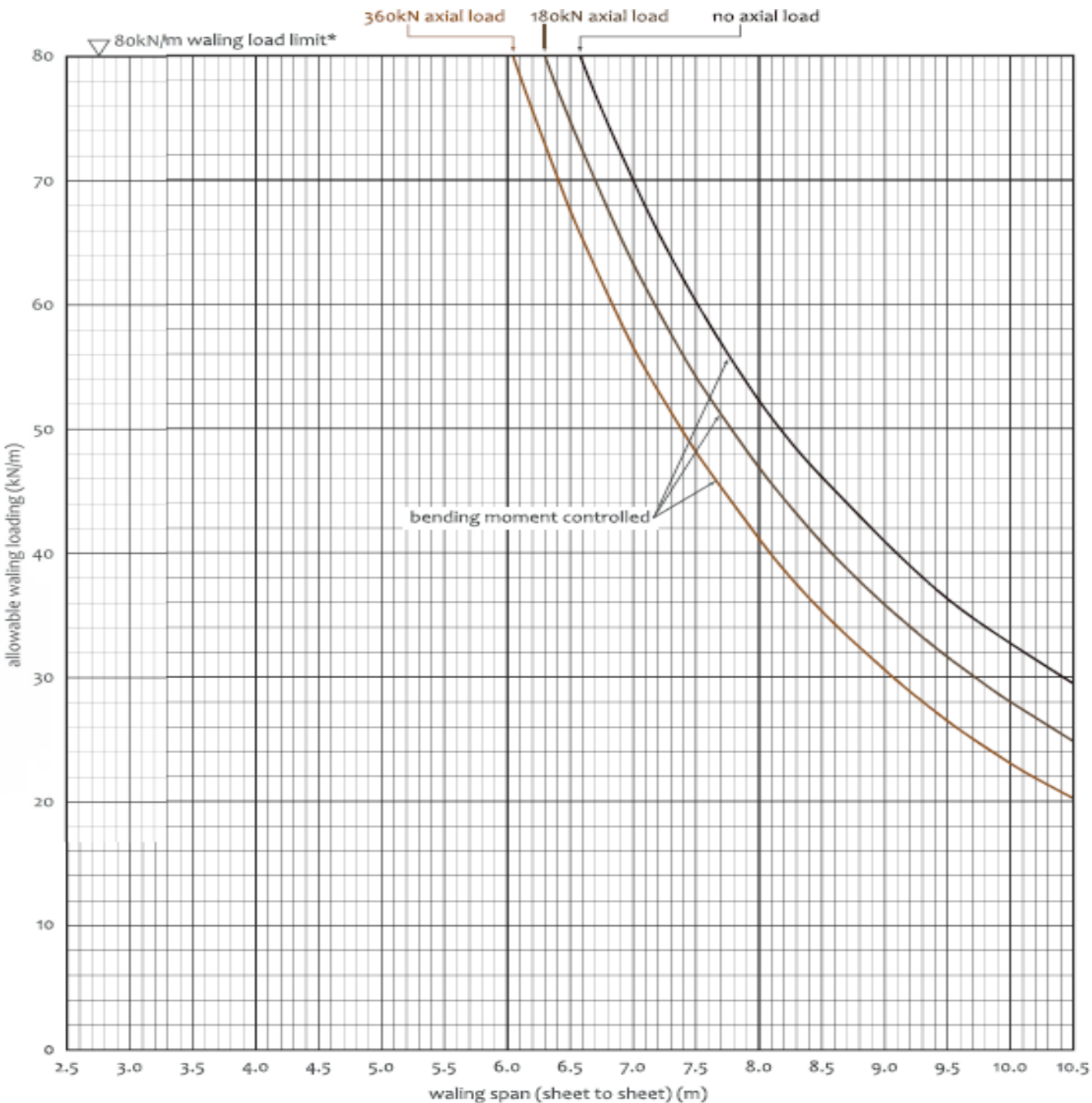

The performance chart above allows for:

- a) A Uniformly Distributed Load (U.D.L) on the waling from sheet piles.
- b) A combined axial loading from adjacent walings.
- c) An allowance for additional secondary bending due to waling deflection

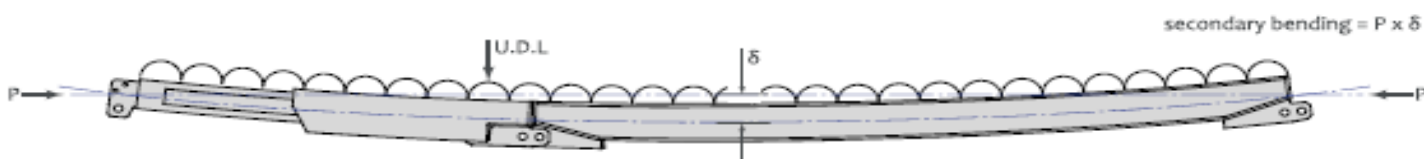

\* For waler lengths shorter than those shown on the above chart it may be possible to increase the allowable rail load above 80kN/m. This could also apply in schemes where the walers are supported by intermediate props or knee braces.

## Super Shaftbrace Typical Build Up Components

Ram Unit Assembly

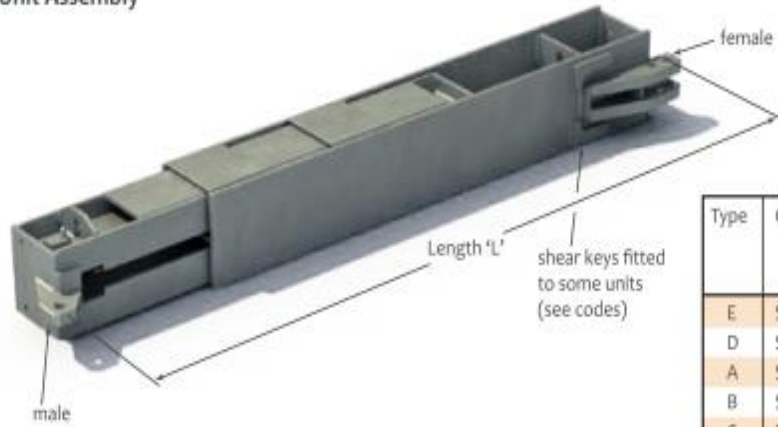

Type	Code*	Length 'L' (mm)		Weight (kg)
		min.	max.	
E	SSB-024	2000	2650	860
D	SSB-010	3000	4000	1123
A	SSB-001	6400	7400	1742
B	SSB-002	8950	9950	2202
C	SSB-003	10650	11650	2538

\* if shear keys are required, add suffix /SK to code

Intermediate Extension Unit  
(356 x 368 U.C.)

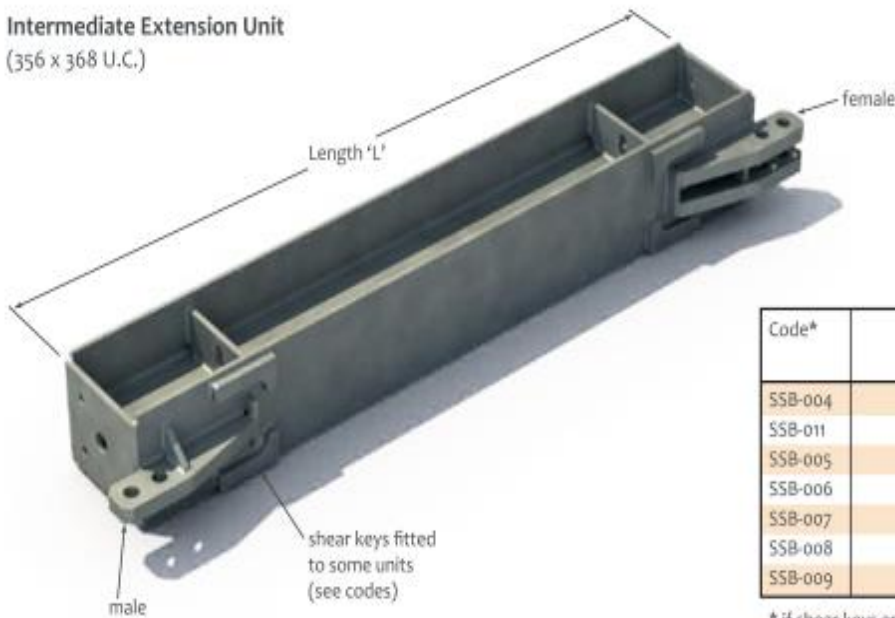

Code*	Length 'L' (mm)	Weight (kg)
SSB-004	850	261
SSB-011	1325	360
SSB-005	1700	431
SSB-006	2550	525
SSB-007	3400	736
SSB-008	6800	1379
SSB-009	11050	2175

\* if shear keys are required, add suffix /SK to code





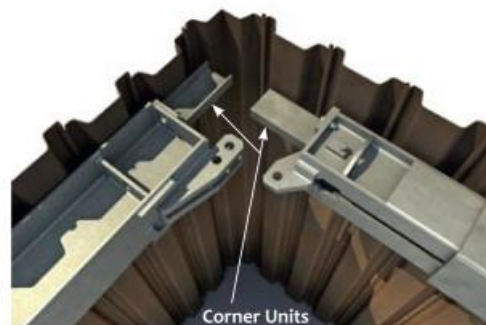









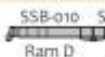

Corner Unit  
Code: SSB-015  
Weight: 16kg

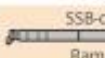

Corner Units

# Hydraulic Bracing Systems (HBS)

## Super Shaftbrace Typical Build Up Components

Leg Arrangement	Leg Code	Clear Internal Dimensions (see notes below)				Corner Pin to Pin Dimension (mm)		Dimension to face of sheet (mm)		Approx. max. Deflection per waling (mm)	Approx. Weight of one Leg (kg)
		Between Waling Flanges except at intermediate connection (mm)		Between Walings at intermediate connection (mm)		min.	max.	min.	max.		
		min.	max.	min.	max.						
 SSB-024 Ram E	SSBLE-01	2140	2790	N/A	N/A	2000	2650	2880	3530	40	897
 SSB-024 SSB-025 Ram E 600	SSBLE-02	2740	3390	2460	3110	2600	3250	3480	4130	40	1107
 SSB-010 Ram D	SSBLD-01	3140	4140	N/A	N/A	3000	4000	3880	4880	40	1160
 SSB-010 SSB-004 Ram D 850	SSBLD-02	3990	4990	3710	4710	3850	4850	4730	5730	40	1430
 SSB-010 SSB-005 Ram D 1700	SSBLD-03	4840	5840	4560	5560	4700	5700	5580	6580	40	1600
 SSB-010 SSB-006 Ram D 2550	SSBLD-04	5690	6690	5410	6410	5550	6550	6430	7430	40	1690
 SSB-001 Ram A	SSBL-01	6540	7540	N/A	N/A	6400	7400	7280	8280	46	1780
 SSB-001 SSB-004 Ram A 850	SSBL-02	7390	8390	7110	8110	7250	8250	8130	9130	60	2040
 SSB-001 SSB-005 Ram A 1700	SSBL-03	8240	9240	7960	8960	8100	9100	8980	9980	80	2200
 SSB-002 Ram B	SSBL-04	9090	10090	N/A	N/A	8950	9950	9830	10830	93	2455
 SSB-002 SSB-004 Ram B 850	SSBL-05	9940	10940	9660	10660	9800	10800	10680	11680	107	2715
 SSB-003 Ram C	SSBL-06	10790	11790	N/A	N/A	10650	11650	11530	12530	121	2790
 SSB-003 SSB-004 Ram C 850	SSBL-07	11640	12640	11360	12360	11500	12500	12380	13380	135	3050
 SSB-003 SSB-005 Ram C 1700	SSBL-08	12490	13490	12210	13210	12350	13350	13230	14230	153	3230
 SSB-003 SSB-006 Ram C 2550	SSBL-09	13340	14340	13060	14060	13200	14200	14080	15080	172	3370
 SSB-003 SSB-007 Ram C 3400	SSBL-10	14190	15190	13910	14910	14050	15050	14930	15930	189	3530

Notes:

1. The clear internal dimensions shown above do not include any allowance for deflection of the walings under load.
2. These waling deflections are listed separately above and generally it will be necessary to increase the clear internal dimensions by twice the appropriate waling deflection.
3. Items denoted "N/A" in the table = Not Applicable
4. Weights for legs using the type 'B' and 'C' ram units are based on the weight for the heavier U.C. 356 x 368 x 202kg/m in Gr50 material.
5. Corner units are fitted to each end of the Super Shaftbrace legs to carry the support for the sheets into the corners of the excavation:

# Hydraulic Bracing Systems (HBS)

## Safe Working Load Charts For Super Shaftbrace

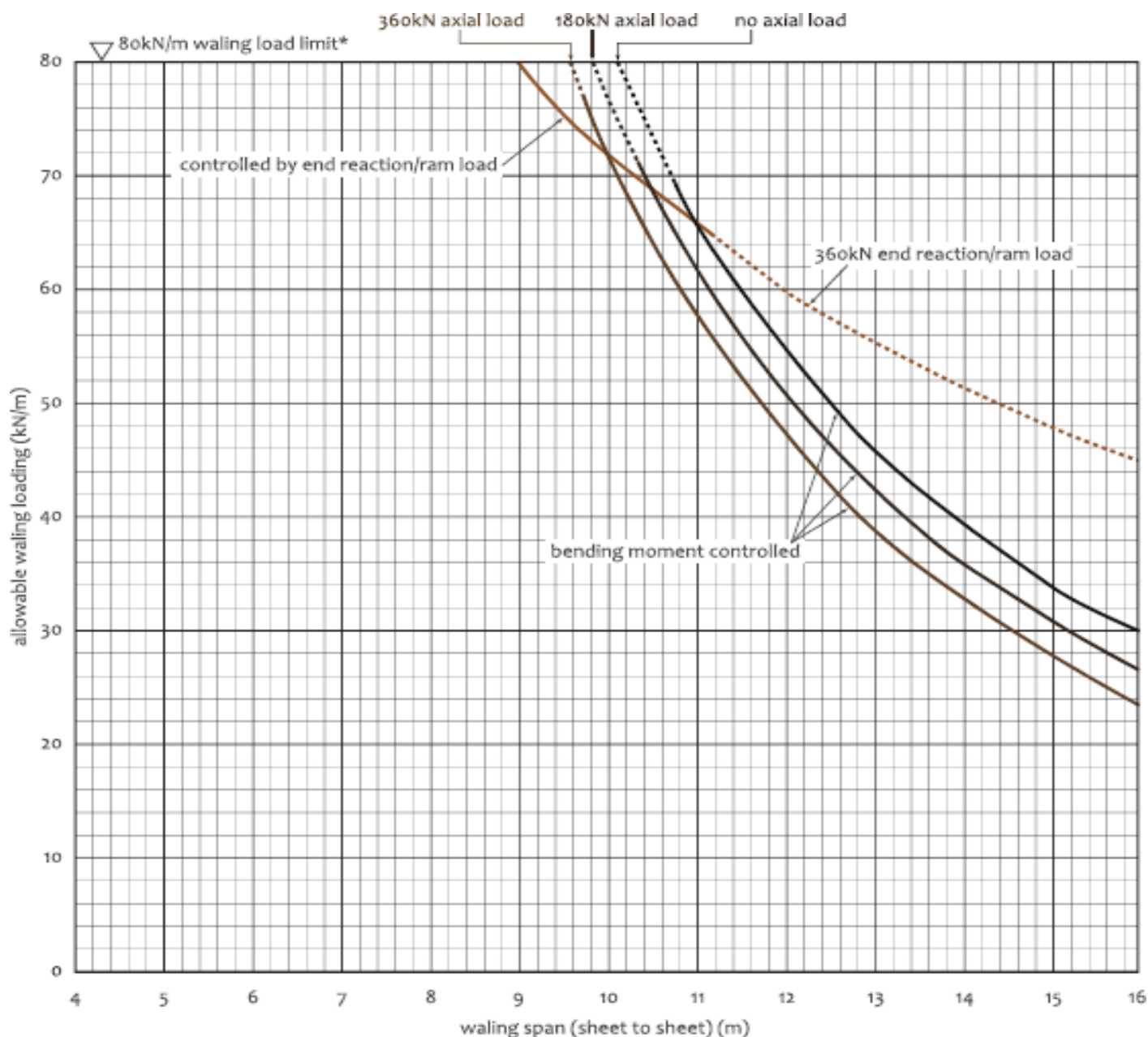

The performance chart above allows for:

- A Uniformly Distributed Load (U.D.L) on the waling from sheet piles.
- A combined axial loading from adjacent walings.
- An allowance for additional secondary bending due to waling deflection

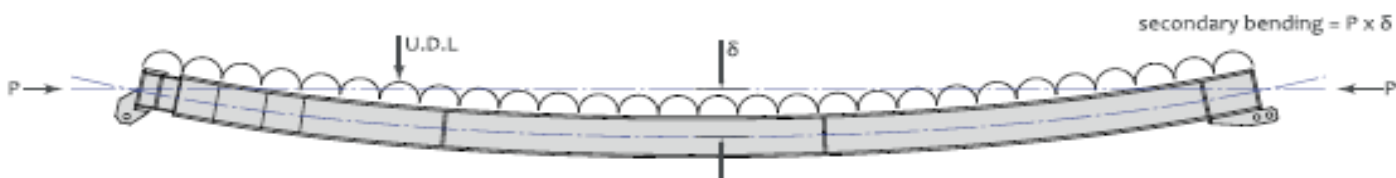

\* For waler lengths shorter than those shown on the above chart, it may be possible to increase the allowable rail load above 80kN/m. This could also apply in schemes where the walers are supported by intermediate props or knee braces.

## Safe Working Load Charts For Mechanical Bracing Strut – Up to 40T

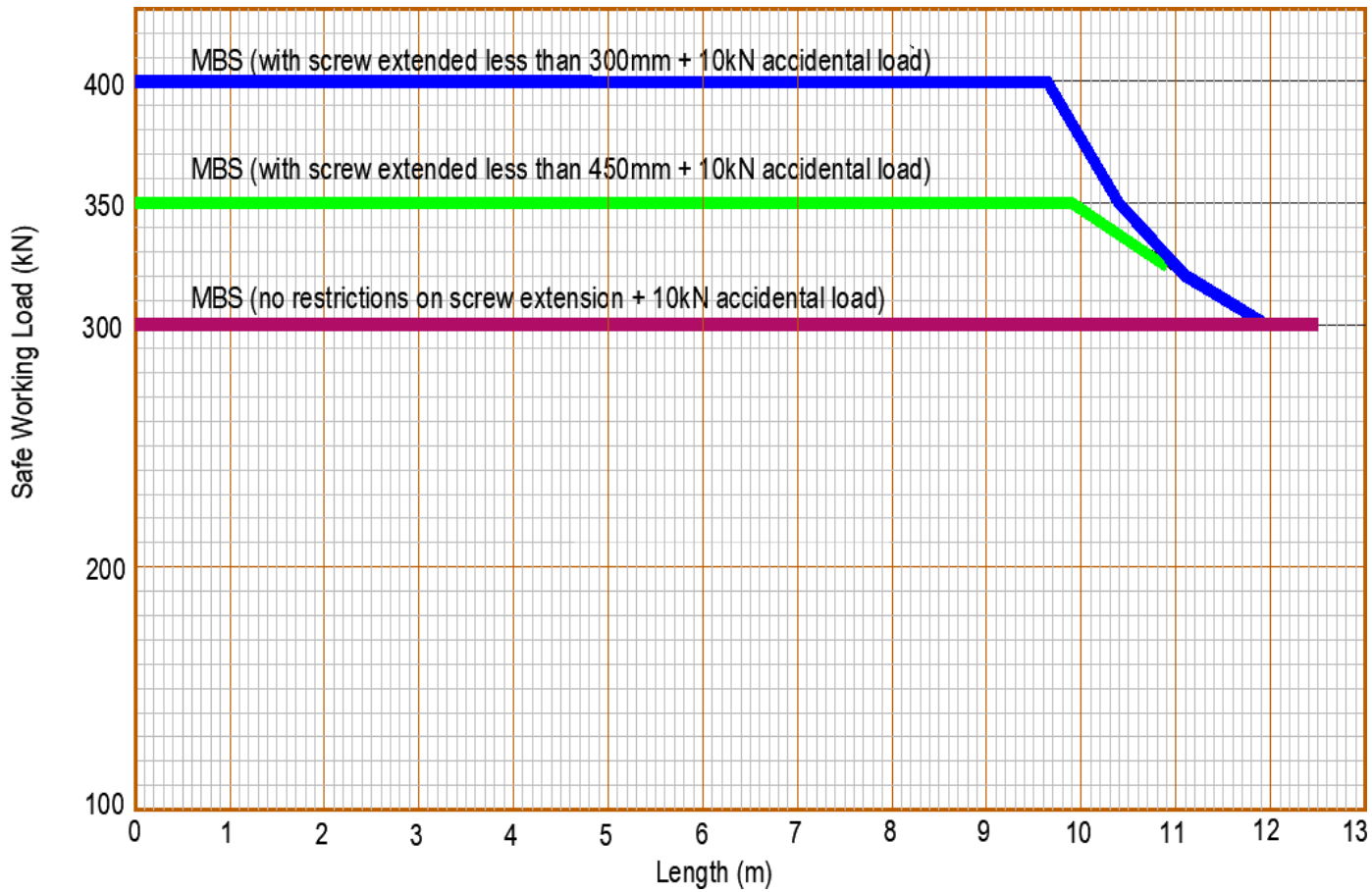

### Performance Criteria

The Values / charts published on pages 10 to 12 are based on:

- Relevant parts of BS449 : 1969 : Part 2
- Testing

Where calculation has been used the following minimum factors of safety have been used:

- In bending = 1.65
- Axial (Rams) = 2.0

All Mabey HBS Systems conform to:

**AS 5047 – 2005 Hydraulic Shoring and Trench Lining Equipment**



## Compatible Safety Products

The same products that connect to the Mabe trench boxes are also connectable to the sheet pile range. **NOTE: Timber packers are required for a tight fit.**

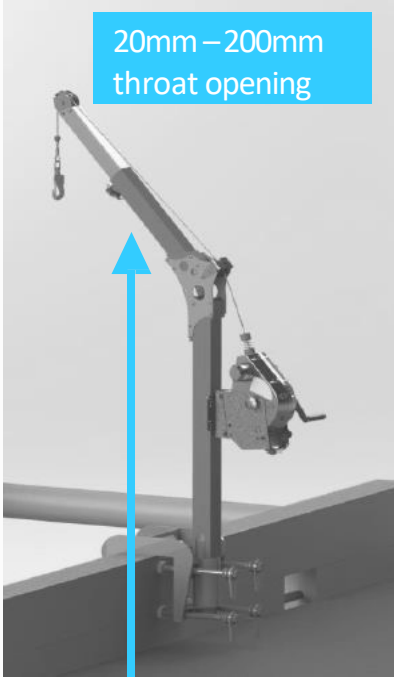

DAVIT ARM

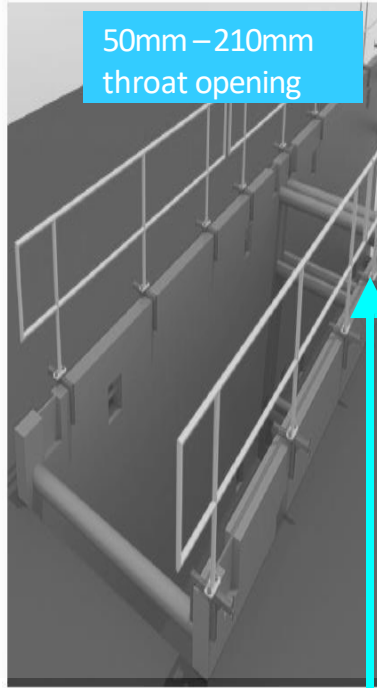

CLAMPING HANDRAILS



LADDER MATE – NEW PRODUCT!



## How can Mabey Engineering add value to your Project?

Mabey's talented Temporary Works Engineering Team will work hard to ensure the success of your project. Our engineers are equipped with top-of-the-line CAD and design software. When necessary, Mabey's team of engineers will design a custom shoring solution using all our modular equipment. **That's; Hydraulic Bracing Systems, Sheet Piling, Trench Boxes, C200 Bridging etc.** We can provide structural design plans and back up calculations when called for by your project.

In addition to our extensive inventory of durable shoring equipment that can be tailored to meet your needs, the expertise of our staff is the reason so many contractors across Australia and New Zealand turn to Mabey as a dependable partner.

## Technical Field Support

While Mabey prides itself on providing easy-to-install solutions, we also understand that each project is unique and may involve complex conditions and unforeseen challenges. Knowing that your reputation is at stake with every project, we offer on-site field support as an added service. Mabey's Engineers, Product Specialists and Area Managers will thoroughly explain the safest and most effective way to use our products so that you can install them quickly and get your project moving. Many of our clients have relied on that extra field support to help them meet critical deadlines and avoid expensive penalties.

## Have a Project where Groundworks Shoring is required?

If you have a project where shoring is needed and you require an Engineered Solution to ensure the proposed equipment is up to the job, then Mabey require certain project specific information in order to do that. The next page highlights the main information Mabey require and suggested attachments.

Required Information:	Comments:
1. Is <b>RPEQ / CPEng</b> or specific <b>Certification</b> Required (Y/N)	
2. <b>Excavation Purpose:</b> (e.g. pipe run, storage tank, wet well etc.)	
3. <b>Plan Dimensions:</b> (state if internal clearance or external dimension provided.)	
4. <b>Excavation Depth:</b>	
5. Are any <b>ground reductions</b> taking place / OR possible? (provide levels):	
6. <b>Ground / Groundwater Conditions:</b> (provide site investigation report, relevant boreholes etc.)	
7. <b>Adjacent Water Courses:</b> (provide details / levels of any nearby rivers, creeks, oceans etc.)	
8. Details of any <b>Dewatering</b> taking place: (e.g. sump pumps / dewatering spears and to what level the water is to be reduced to.)	
9. Details of <b>Plant / Excavators / Cranes etc.</b> working around Excavation: (provide weights and distances.)	
10. Details of any additional <b>nearby Loads:</b> (e.g. Spoil, Live Roads, Railways, Buildings etc.)	
11. Any <b>height restrictions</b> on use of lifting plant: (e.g. max lift height of excavator / overhead power cables.)	

## Suggested Attachments

- Shoring Structure Location map(s) & OR Sketch of Site Layout
- Photographs.
- Long sections.
- Existing Structures & proposed Structure drawings (if possible in AutoCAD format).
- Relevant borehole / trial pit.
- Full Soil Survey Report.
- Others / Any relevant documents.



enabling global infrastructure

## LOCATIONS

AUSTRALIA

Head Office  
37 Access Avenue,  
Yatala,  
QLD,  
4207  
[info@mabey.com.au](mailto:info@mabey.com.au)  
07 3209 7172

Melbourne Hallam Branch  
4 Technology Circuit,  
Hallam,  
VIC,  
3803  
[melbourne@mabey.com.au](mailto:melbourne@mabey.com.au)  
+61 (0)3 8786 3988

Brisbane Branch  
37 Access Avenue,  
Yatala,  
QLD,  
4207  
[brisbane@mabey.com.au](mailto:brisbane@mabey.com.au)  
+61 (0)7 3287 4233

Melbourne Sunshine West Branch  
185 Fairbairn Rd,  
Sunshine West,  
VIC,  
3020  
[melbourne@mabey.com.au](mailto:melbourne@mabey.com.au)  
+61 (0)3 9311 2611

Sunshine Coast Branch  
227-229 Nambour Connection Rd,  
Woombye,  
QLD,  
4559  
[sunshinecoast@mabey.com.au](mailto:sunshinecoast@mabey.com.au)  
+61 (0)7 5442 3000

Perth Branch  
100 Daddow Rd,  
Kewdale,  
WA,  
6105  
[perth@mabey.com.au](mailto:perth@mabey.com.au)  
+61 (0)8 9359 1871

Sydney Branch  
16-26 Lugard St,  
Penrith,  
NSW,  
2750  
[sydney@mabey.com.au](mailto:sydney@mabey.com.au)  
+61 (0)2 4721 8832

NEW ZEALAND

Auckland Branch  
7 Bolderwood Place,  
Wiri,  
Auckland,  
2104  
[auckland@mabey.co.nz](mailto:auckland@mabey.co.nz)  
0800 622 394

Christchurch Branch  
207 Main South Rd,  
Sockburn,  
Christchurch,  
8042  
[christchurch@mabey.co.nz](mailto:christchurch@mabey.co.nz)  
0800 622 394