

# PRODUCT USER GUIDE

## ULTRA SHIELD

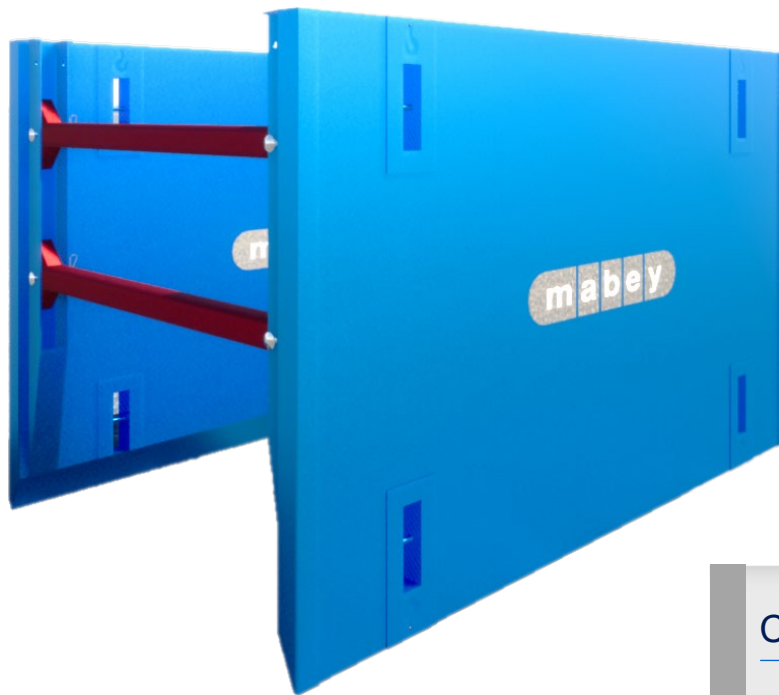

### Introduction

This booklet is intended to provide basic information for users of the Mabey Hire Ltd Aluminium Trench Shields system and to draw the client's attention to the practical aspects of Aluminium Trench Shields operational procedures and basic maintenance which need to be considered when compiling method statements, risk assessments and safe system of works. It is assumed that clients are familiar with general safe practices applicable to this type of work.

The Aluminium Trench Shields are intended to be used in trenches for which the excavation is being undertaken with small excavators that do not have the lifting capacity to work with standard, heavier, trench box systems. All major components of the Aluminium Trench Shield system have handling and lifting points for safe slinging. It is not intended for other purposes.

Aluminium Trench Shields are not normally suitable for use in water bearing soils or in trenches crossed by frequent services. Trench Shields systems should not be used in seawater applications without prior consultation with the Mabey Hire Ltd. Engineering Department.

It is advisable, before commencing installation, to read the notes below and to become familiar with the procedures involved when using the Aluminium Trench Shield.

### Configuration Available

- ▶ 2-Sided Trench Box
- ▶ 4-Sided Trench Box
- ▶ 2-Sided Wing Return Manhole Boxes

### IMPORTANT NOTES

All excavation work must be thoroughly planned before work commences on site to identify hazards and assess risk.

These instructions form guidance for the typical installation of Trench Box Equipment. Non-standard applications should be approved by a suitably qualified engineer.

Ensure all personnel engaged in installation operations are properly briefed and adequately supervised by a competent person,

All hire for this equipment will usually be accompanied by a general arrangement or scheme specific drawing. This must be read in conjunction with these instructions.

[WWW.MABEY.COM.AU](http://WWW.MABEY.COM.AU)

AUS: 1800 622 394

NZ: 0800 622 394



Uncompromising Service  
to Deliver Successful  
Projects

## Contents

### 1. General Guidance Notes

▶ Safe System of Work and Method Statement .....	3
▶ Access, Hard standing Areas and Site Storage .....	3
▶ Personnel.....	3
▶ Plant and Lifting Equipment.....	3
▶ Sling Warning .....	3
▶ Small Plant, Tools and Lifting Chains.....	3
▶ Access & Egress and Edge Protection.....	3
▶ During Installation Works .....	3
▶ After Installation Works .....	3
▶ Return of Equipment Off-Hire.....	3

### 2. Component Identification

▶ Shield Panels.....	4
▶ Extension Connector & Corner Connection .....	4
▶ Shield Details.....	5
▶ 4- Sided Box Details .....	6
▶ Strut Details .....	6
▶ High Clear Arch & Connectors .....	7
▶ Protection Components .....	7

### 3. Before Installation .....

8

### 4. Typical Site Assembly - Lifting & Installation .....

9

▶ Shield Panels.....	9
▶ Manhole .....	10
▶ High Clear Arches.....	11
▶ Square Box .....	12

### 5. Extraction of an Ultra Shield Box.....

13

### 6. General

▶ Basic Maintenance .....	13
▶ Do's & Don'ts .....	13

## 1. General Guidance notes

### Safe System of Work

Assuming that the appropriate Aluminium Trench Shields has been selected for use, the Health and Safety at Work Act requires that a safe system of work is adopted to carry out the works on site.

These guidance notes are intended to draw the client's attention to practical aspects of Mabey Hire Pty. range of Aluminium Trench Shields components during use and basic maintenance which need to be considered when completing method statements for a safe system of work.

### Access, Hard standing Areas and Site Storage

- Suitable firm, level, dry areas should be made available on site for storage and pre-assembly work.
- Suitable lifting equipment of adequate capacity should be provided for off-loading and installation.
- Slings should always be carried out by suitably experienced and competent personnel.
- The weights of components and assemblies are given in this guide.
- Large components should be stacked, nested with suitable timber dunnage, max 3no panels per stack.
- Smaller components should be stored in skips/bins.

### Personnel

The Management of Health and Safety at Work Regulations require that personnel deployed are suitably trained, experienced, and supervised by a competent person.

The main activities associated with Aluminium Trench Shields use are:

- Unloading and loading the delivery vehicle.
- Pinning components together.
- Slings and lifting the Aluminium Trench Shields into and out of the trench.

### Plant and Lifting Equipment

A suitable appliance is required for off-loading, installation, and re-loading of equipment, together with lifting chains, available from Mabey Hire Pty Ltd., of suitable length and capacity and with current certification.

### WARNINGS:

- If Aluminium Trench Shields components are to be lifted in or around an excavation, the appliance should be located at a safe distance from the edge of the excavation and the lifts and radii checked against the safe lifting capacities of the appliance. A surcharge for the appliance must have been allowed for in the excavation brief / design.
- No more than one assembled component must be lifted at a time.

### Sling Warning

If a sling is to be used on an excavator, be aware of the following:

- It is very important that a means of allowing the sling to swivel be introduced above the master (top) ring. This will allow the sling, and in particular the master ring, to turn and align with the load.
- Without a swivel arrangement, the load may severely twist the master ring, resulting in damage or failure.
- All lifting accessories attached to the excavator lifting point must hang freely and be free to move at all times.

### Small Plant, Tools and Lifting Chains

- Lifting Chains of suitable length and capacity complete with current certification. Typically for Aluminium Trench Shield a set of 4 leg 7mm chains with 4m leg length.

### Access & Egress and Edge Protection

- Install the edge protection as soon as possible before entry into the excavation.
- A competent person should inspect the means of access and egress regularly.

### During Installation Works

- Check that all bolted connections remain tight.
- Check that all pinned connections are intact and complete with an 'R' clip, where required.
- Avoid striking equipment or loading it inappropriately.

### After Installation Works

Each excavation must be inspected daily before personnel begin work.

### Return of Equipment Off-Hire

Clients should ensure that on removal, the equipment is returned clean and assembled as supplied.

Ensure all equipment is loaded to the satisfaction of the vehicle driver and is securely restrained to the vehicle bed.

## 2. Component Identification

### 2.1 Shield Panels

<b>PL</b>	Panel Length
<b>PH</b>	Panel Height
<b>PW</b>	Panel Width
<b>CLS</b>	Clearance Length Sturt to Strut
<b>MW</b>	Min. & Max. Width
<b>UC</b>	Under Strut Clearance
<b>EXTENSION</b>	Upper Panel
<b>LOWER</b>	Lower Panel

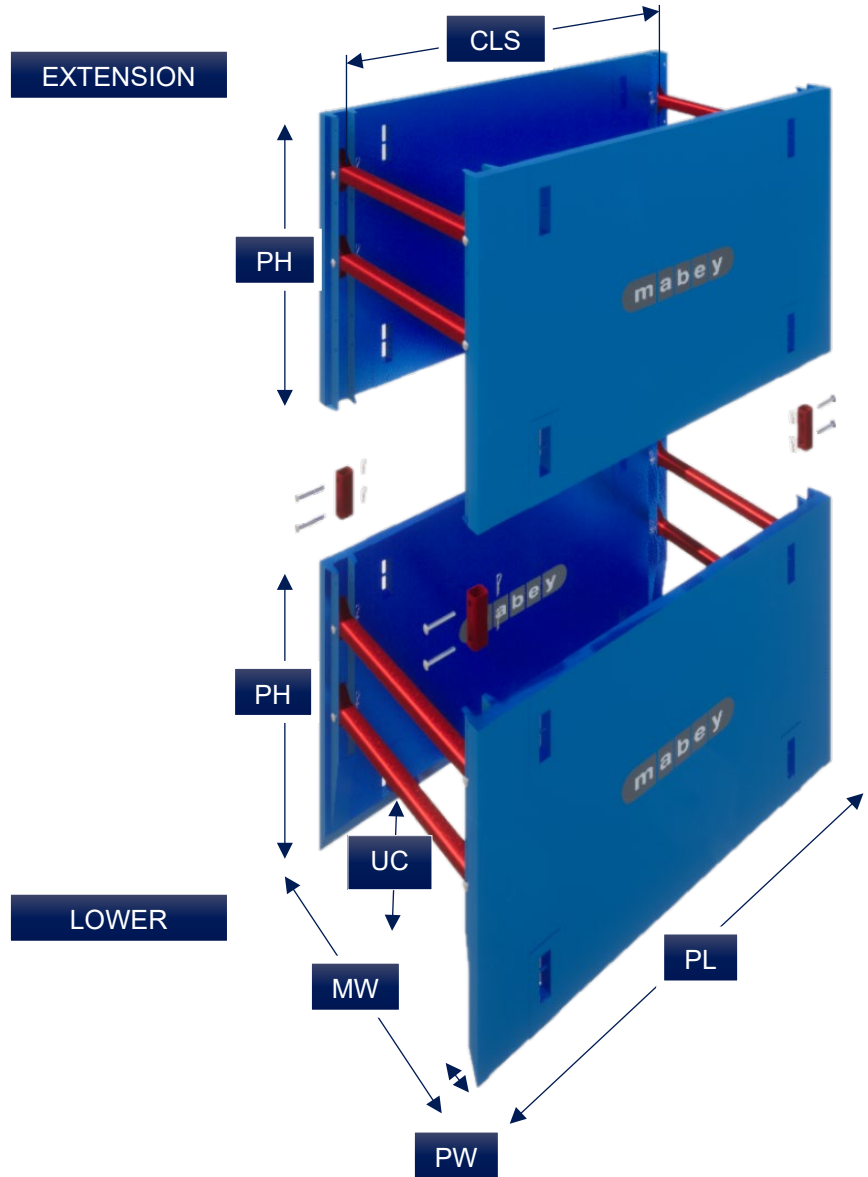

### 2.2 Extension Connector & Corner Connection



Extension Connector  
Weight: 7.5 kg  
Dimensions: 100x100x9mm  
Length: 300mm



Corner Strut Connector 4-Sided Box  
Weight: 25.0 kg  
Dimensions: 100x100x9mm

### 2.3 Shield Details

Panel Type	Panel Length PL (mm)	Panel Height PH (mm)	Panel Width PW (mm)	Clearance Length CLS (mm)	Min Width MW (mm)	Max Width MW (mm)	Under strut Clearance UC (mm)	Safe Working Load (kPa)	Unit Weight (kg)
<b>Manhole Base</b>	2,000	2,000	56	1,850	2,000	4,000	560	30	140
<b>Manhole Base</b>	2,400	2,400	90	2,200	2,000	4,000	1,150	50	400
<b>Lower</b>	1,800	2,000	90	1,480	600	4,000	900	50	100
<b>Extension</b>	1,800	1,600	90	1,480	600	4,000	350	50	70
<b>Lower</b>	3,100	2,000	90	2,780	600	4,000	900	50	260
<b>Extension</b>	3,100	2,000	90	2,780	600	4,000	550	50	260
<b>Lower</b>	3,600	2,400	90	3,280	600	4,000	1,350*	36	400
<b>Extension</b>	3,600	2,000	90	3,280	600	4,000	950	36	325
<b>Lower</b>	4,000	2,400	150	3,680	600	4,000	1,350*	70	550
<b>Extension</b>	4,000	2,000	150	3,680	600	4,000	950	70	430
<b>Lower</b>	6,000	2,400	150	5,700	600	4,000	1,350*	45	850
<b>Extension</b>	6,000	2,400	150	5,700	600	4,000	1,100	45	850
<b>Lower</b>	7,200	2,400	150	6,880	600	4,000	1,350*	36	1,000
<b>Extension</b>	7,200	2,400	150	6,880	600	4,000	1,100	36	1,000

\* NOTE: 2.4m Under strut is possible with High Clear Arches



Ultra-Shield Lower  
Weight: Refer Table

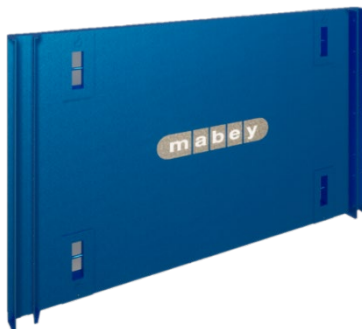

Ultra-Shield Upper  
Weight: Refer Table



Ultra-Shield Manhole  
Weight: Refer Table

## 2.4 4- Sided Box Details

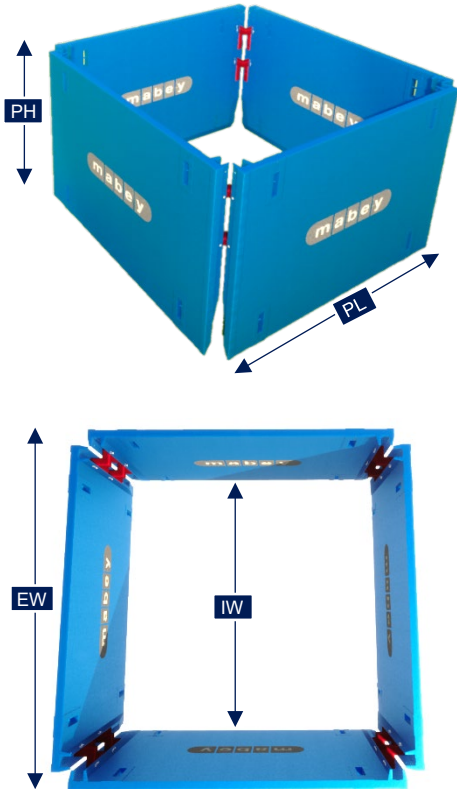

Panel Type	Panel Length PL (mm)	Panel Height PH (mm)	Internal Width IW (mm)	External Width EW (mm)	Safe Working Load (kPa)	Unit Weight (kg)
Lower	1,800	2,000	1,990	2,180	50	600
Extension	1,800	1,600	1,990	2,180	50	480
Lower	3,100	2,000	3,290	3,480	50	1240
Extension	3,100	2,000	3,290	3,480	50	1240
Lower	3,600	2,400	3,790	3,980	36	1800
Extension	3,600	2,000	3,790	3,980	36	1500
Lower	4,000	2,400	4,190	4,500	70	2400
Extension	4,000	2,000	4,190	4,500	70	1920
Lower	6,000	2,400	6,190	6,500	45	3600
Extension	6,000	2,400	6,190	6,500	45	3600
Lower	7,200	2,400	7,390	7,700	36	4200
Lower	7,200	2,400	7,390	7,700	36	4200

**Note:**

If boxes are double stacked (Upper & Lower), 4-sided corner sections can only be used on Lower boxes that are 2.4m high. Where 2.0m high panels must be double stacked, use (Upper & Upper) combination instead.

## 2.5 Strut Details



Length (mm)	600	800	1000	1200	1500	1800	2000	2100	2500	2800	3000	3500	3800	4000	6000	7200
Weight (kg)	15	20	25	30	37.5	45	50	52.5	62.5	70	75	87.5	95	100	192	230

\*100 x 100 x 9 SHS used up to 3m Long – 25 kg /m

\*\* 150 x 100 x 9 RHS used from 3.0m to 4.0m Long - 32kg/m

## 2.6 High Clear Arch & Connector Pin

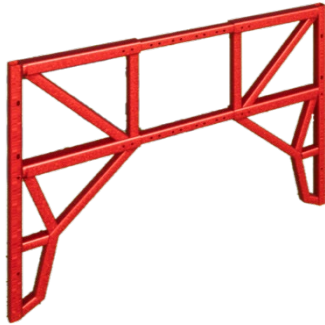

High Clear Arch

Weight: 500 kg

Dimensions: 100x100x9mm

Length: 2100mm to 4000mm

\*Suitable on 3.6m to 7.2m Long Lower Panels Only



Connector Pin & "R" Connector

Weight: 0.1 kg

Dimensions: ø12mm Shank x 90mm Long

## 2.7 Protection Components

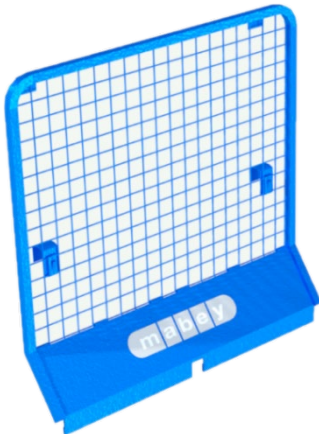

Sheet Guard Barrier

Weight: 21.5 kg



Access Platform

Weight: 110 kg

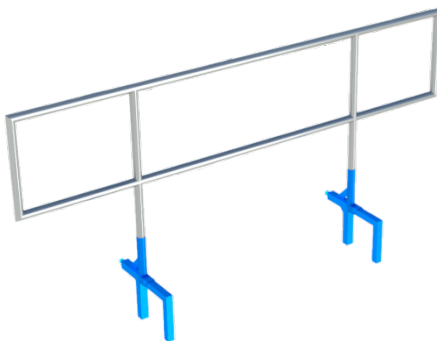

Aluminum Handrail

<b>Length</b>	2.5m	3.0m	4.0m
<b>Weight</b>	25 kg	33 kg	40 kg



Davit Arm

Weight: 42 kg

### 3. Before Installation

#### Maximum Depth

Generally Suited to a lower and upper box assembly configuration. However, dependant upon ground conditions and installation method, greater shored depths maybe achievable.

#### Deflection

As per AS4744.1 Section 5.3., the Maximum Span in the system is defined by **Span/60**. ie., distance between struts.

#### Rated System Capacity

Users are advised to check that their excavations will not impose greater working earth pressures than the recommended.

For working earth pressures of Ultra Shield System Box and Manhole Box, please refer Shield Details Table page 5.

#### Pulling Force

The minimum WLL of a single lifting point on any box panel 3.0T (FOS of 3) or 12T for 4no. lifting points. This rated capacity is for any angle between vertical and 60° from vertical.

A minimum of 2 chains must always be used when lifting individual box panels. A minimum of 4 chains must always be used when lifting built up box system. Additional care must be used if using a single chain to pull on lifting points where a trench box system is held tightly in the ground.

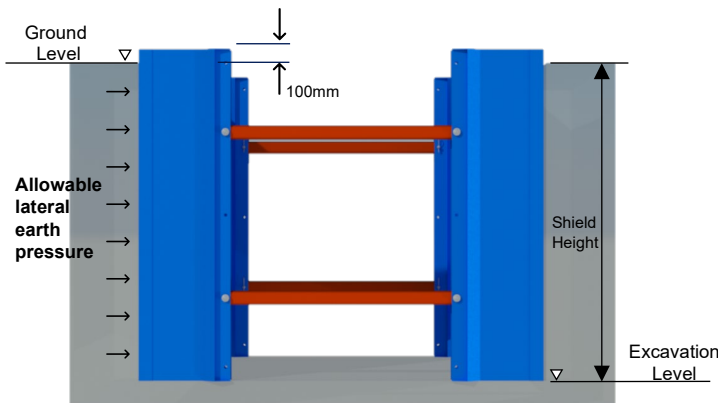
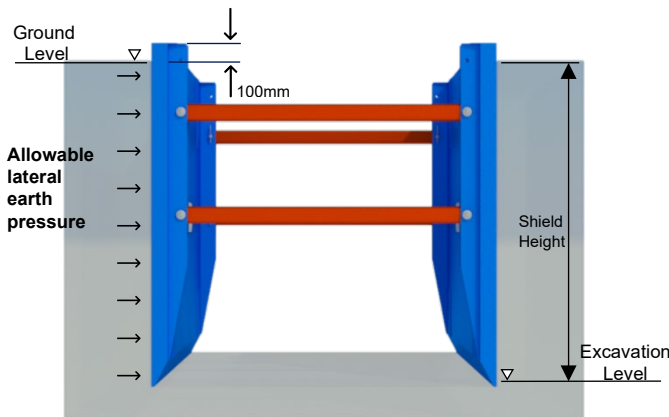

### 4. Typical Site Assembly - Lifting & Installation - Shield

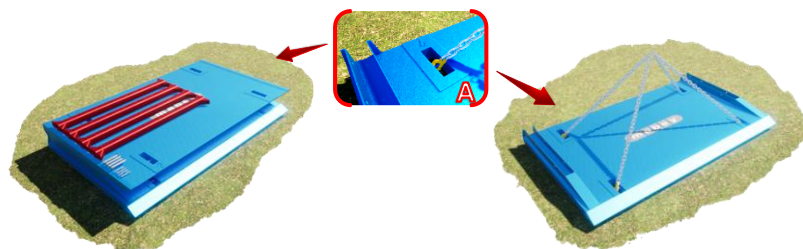

1. Remove panels from the truck by lifting panels with 4 point lift lugs. Detail "A"

2. Place a panel flat on the ground with the collars/channel/ribs facing up.

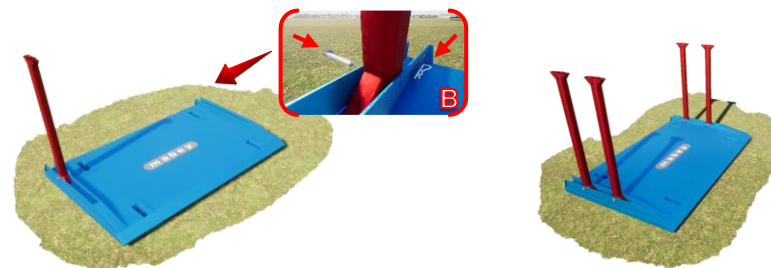

3. Connect the struts to the panel using the pins and clips, as shown in Detail B. The "R" clips should always be on the inside of the channel for any Ultra Shields to protect them.

4. Check all strut are properly attached and secure before place and connect the second panel

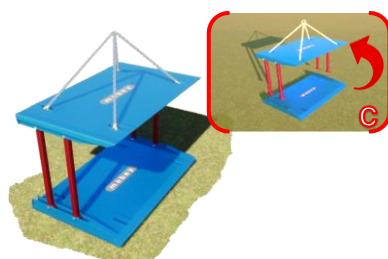

5. Lift the second panel onto the struts and secure with the pins and clips. For struts longer than 3.0m, lay second panel on the ground and connect as shown in Detail C.



6. Lift the unit slowly into a standing position using either a four-leg chain or sling connected to the lifting lugs provided (2 per panel at the top edge).



7. Pre-excitation max. 1.0 m and not more than one shoring section length. In principle the pre-excitation complies with the type of soil and safety regulations. We advise expressly that it forbidden to enter the danger area during the installation and during the reinstallation.

8. Check to make sure all pins and clips are secure. Once the trench is dug to the required width and depth, lift the shield(s) using the four-leg chain sling attached to the four lifting points at the top of the uppermost pair of panels and place the shield into the pre-dug trench.



9. If the shield is not on the base of the excavation, gently with the machine push each corner down to make sure the shield is safely in place and will not suddenly slide down into the excavation.



10. Continue to excavation to level by dig and push. Once the shield is in place, remove the chains or slings. Leave the top of the shield 100mm above the surrounding ground level. **Do NOT** use any unsupported part of the trench for access.

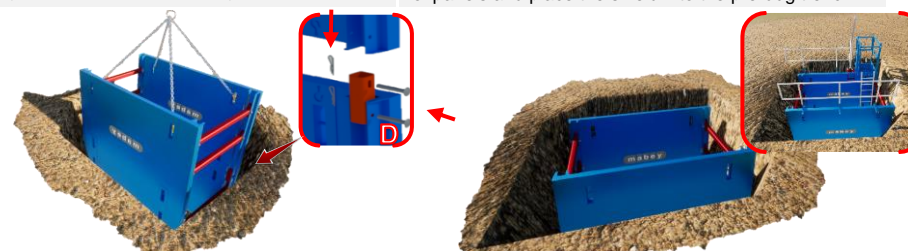

11. If the trench depth requires multiple shields, they can be connected on top of each other using the "Extension Connector" bracket and its clips, as shown in Detail "D". Once the shield is in place, remove the chains or slings. If the shield is not on the base of the excavation use the dig and push method.

12. Backfill any gap between the pre-dug trench and the shoring box. The ends of the shoring should be suitable benched or have suitable end panels that **Do NOT** bare onto the struts. It is Advisable the use of Safety Equipment.

### 4.1 Typical Site Assembly - Lifting & Installation - Manhole

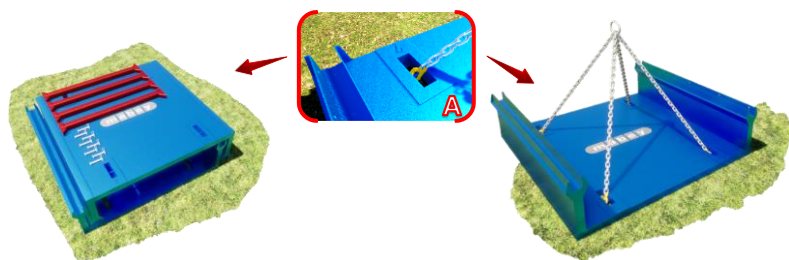

1. Remove panels from the truck by lifting panels with 4 point lift lugs. Detail "A"

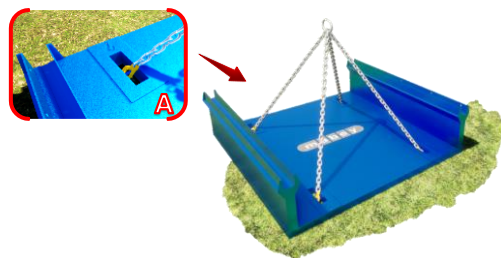

2. Place a panel flat on the ground with the collars/channel/ribs facing up.

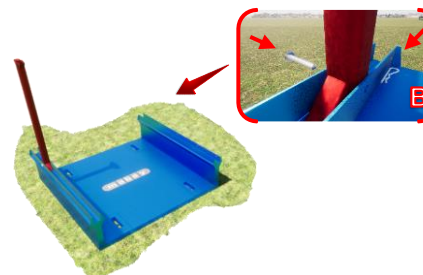

3. Connect the struts to the panel using the pins and clips, as shown in Detail "B". The "R" clips should always be on the inside of the channel for any Ultra Shields to protect them.

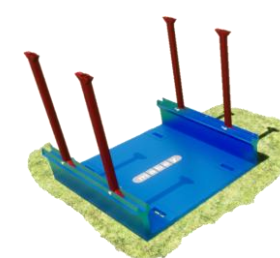

4. Check all strut are properly attached and secure before place and connect the second panel

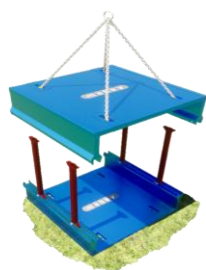

5. Lift the second panel onto the struts and secure with the pins and clips. Not suitable for struts longer than 3.0m.



6. Lift the unit slowly into a standing position using either a four-leg chain or sling connected to the lifting lugs provided (2 per panel at the top edge).

Do NOT lift the shield with the chain sling attached to the struts.



7. Pre-excavation max. 1.0 m and not more than one shoring section length. In principle the pre-excavation complies with the type of soil and safety regulations. We advise expressly that it forbidden to enter the danger area during the installation and during the reinstatement.

Ensure the struts are horizontal and at right angles to the panels.



8. Check to make sure all pins and clips are secure. Once the trench is dug to the required width and depth, lift the shield(s) using the four-leg chain sling attached to the four lifting points at the top of the uppermost pair of panels and place the shield into the pre-dug trench.



9. If the shield is not on the base of the excavation, gently with the machine push each corner down to make sure the shield is safely in place and will not suddenly slide down into the excavation.



10. Continue to excavation to level by dig and push. Once the shield is in place, remove the chains or slings. Leave the top of the shield 100mm above the surrounding ground level. Do NOT use any unsupported part of the trench for access.



11. If the trench depth requires multiple shields, they can be connected on top of each other using the "Extension Connector" bracket and its clips, as shown in Detail "C". Once the shield is in place, remove the chains or slings. If the shield is not on the base of the excavation use the dig and push method.

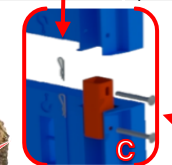

12. Backfill any gap between the pre-dug trench and the shoring box. The ends of the shoring should be suitable benched or have suitable end panels that Do NOT bare onto the struts. It is Advisable the use of Safety Equipment.

**IMPORTANT:** The Ultra High Clear Arch System creates a stiff and rigid shoring system that Does Not allow significant Panel / Strut movement and is therefore more suitable for Dig and Drop Installation Method.

## 4.2 Typical Site Assembly - Lifting & Installation - High Clear Arches

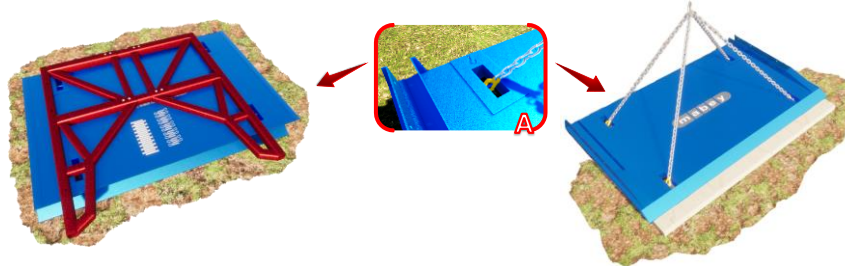

1. Remove panels from the truck by lifting panels with 4-point lift lugs. Detail "A"

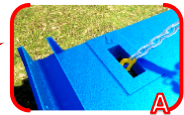

2. Using a 4-leg chain connected to all lifting points, lift one lower box panel and place it on timber skids, with strut channels facing upwards. Detail "A".

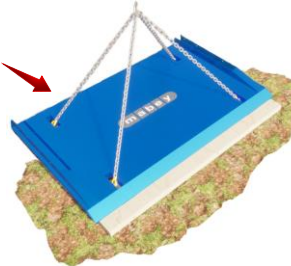

Ensure **pin holes** on strut channels and high clear arch **are aligned**



Additional Support Recommended

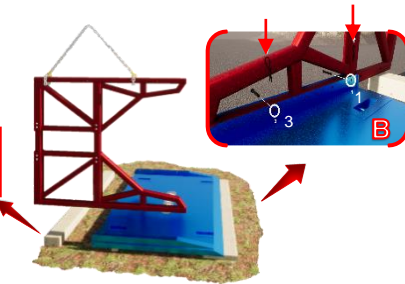

3. High Clear Arches will always be delivered to site pre-assembled to the required size.

4. Lift the pre-assembled high clearance arches and lower into the strut channels. Install pins and clips at designated locations "Detail B".

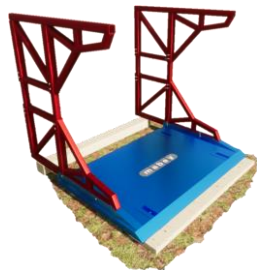

5. Repeat the process to install high clearance arch on the other channel. Check the arches are properly attached and secure before place and connect the second panel

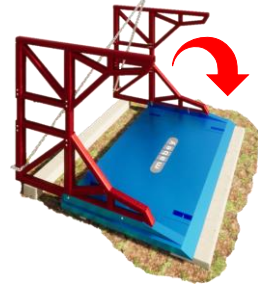

6. Attach two hanging chain legs to the high clear bars. Rotate the assembly as shown until the unit is safely positioned with the base of the arch on the ground. "Detail C"

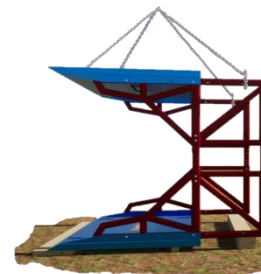

7. Position the arches and struts and ensure pin holes on the struts / arches on the panels are aligned Detail "D". Install pins and clips. Attach 4 hanging chain legs with 2 to the lower lifting lugs of the upper panel and 2 to the arches. Shorten or relocate lifting points of chains where required, to rotate the shoring box assembly as shown.

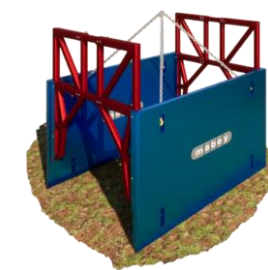

Ensure the struts are horizontal and at right angles to the panels.

8. Lift the unit slowly into a standing position using either a four-leg chain or sling connected to the lifting lugs provided (2 per panel at the top edge).



Do **NOT** lift the shield with the chain sling attached to the struts.

9. Pre-excavation should be not more than one shoring section length. In principle the pre-excavation complies with the type of soil and safety regulations. We advise expressly that it forbidden to enter the danger area during the installation and during the reinstatement.



10. Lower the shoring box assembly into a pre-dug trench, providing that stability of this temporarily un-supported trench is assessed as stable throughout the duration of the work.



11. Once the shield is in place, remove the chains or slings. Backfill any gap between the pre-dug trench and the shoring box. Install end panels assemblies, if and where required. It is Advisable the use of Safety Equipment.

UPPER AND LOWER SHIELD ASSEMBLE

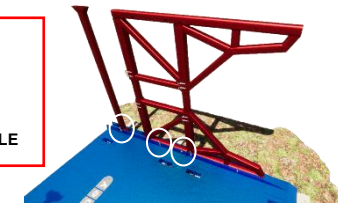

12. Lift lower and Upper Shields and place them on timber skids, with strut channels facing upwards. Lift the pre-assembled high clearance arches and lower into the strut channels and install pins and clips at designated locations. Lastly, install standard struts on the upper box panel as shown. Continue step "5"

**IMPORTANT:** The Ultra Square Box System creates a stiff and rigid shoring system that Does Not allow significant Panel / Strut movement and is therefore more suitable for Dig and Drop Installation Method.

4.3 Typical Site Assembly - Lifting & Installation – Square Box – (Four sided boxes can be very heavy therefore only a lower is shown in the installation sequence)

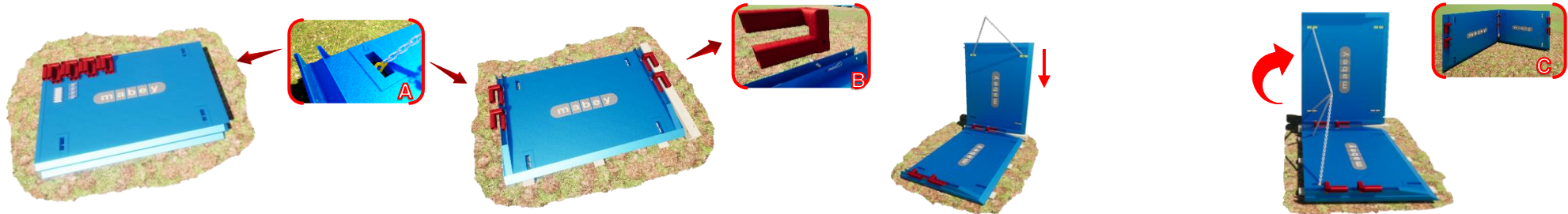

**1A.** Remove panels from the truck by lifting panels with 4-point lift lugs. Detail "A"

**2A.** Using a 4-leg chain connected to all lifting points, lift one lower box panel and place it on timber skids, with strut channels facing upwards. Pin the four corner struts into the panel using standard pins and 'R' clips provided as shown in Detail "B"

**3A.** Connect the corner struts into the second panel using pins and 'R' clips provided. The customer is to provide adequate support to prevent overturning of the system. Pin and corner strut must be connected at the same location that is suggested in standard box construction.

**4A.** Attach 4 chains to four upper lifting points and carefully rotate the panel assembly to a standing position. The assembly shall remain on a stable, firm, and flat ground surface. Detail "C". Continue Step "5"



**1B.** Using a 4-leg chain connected to all lifting points, lift one lower box panel and place it on timber skids, with strut channels facing upwards. Detail "A". Pin the four corner struts into the panel using standard pins and 'R' clips provided.

**2B.** Excavate two trenches (as shown). Trench should work as a temporary support for two (perpendicular) panels to stand vertically. Lower first panel into the trench. customer is to ensure that the trench will always remain stable.

**3B.** Lower the second panel into the trench. Ensure there is enough reach and maneuvering space for a site personnel to connect the two panels. Pin the corner struts into the second panel using pins and 'R' clips provided.

**4B.** Attach 4 chains to the upper lifting points and lift the box out of the trench. Relocate the assembly to rest on a stable, firm and flat ground surface. As shown Detail "D"

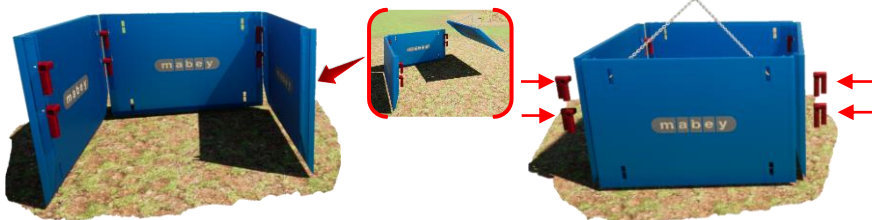

**5.** Ensure the second and third panel are parallel, leaving enough clearance to install the fourth panel. Standard strut can be, alternatively, used on the end opening to create a three-sided shoring system.

**6.** Connect the fourth panel to the assembly using four corner struts, pins and 'R' clips provided.

Do **NOT** lift the shield with the chain sling attached to the struts.



An Upper box maybe added and connected to a lower using extension connectors



**7.** Attach 4 chains to the upper lifting points and lower the box assembly into the pre-dug hole. The customer is to ensure this temporarily unsupported excavation is stable throughout the duration of the work.

**8.** Backfill any gap between the pre-dug excavation and the shoring assembly with self-compacting materials. Excavator and site personnel are to be located at a safe distance away from the excavation when the box assembly is lowered into the excavation.

## 5. Extraction of an Ultra Shield Box



To extract the shield from the trench, attach the chain sling as for installation (using the four topmost lifting points on the shield) and lift the shield vertically out of the trench.

If the shield is tight in the trench, place the lifting chains on the two lifting lugs at one end of the shield. Lift this end of the shield slightly and then reposition the chains to the other end of the shield and lift slightly.

Continue to swap the chains from one end of the shield to the other, lifting slightly each time until the shield is loose in the trench and can then be removed in the normal fashion using all four legs of the sling on the top four lifting points.

## 6. General

### Basic Maintenance

- ▶ Regularly check that all pins are in place and 'R' clips fitted.
- ▶ Replace damaged components.
- ▶ Remove debris from Pins and 'R' clips.
- ▶ Avoid laterally loading the struts-either by hanging or propping from them or accidentally striking them with site plant.

### Do's and Don'ts

- ▶ DO use a ladder to enter the working space between the struts of the shield.
- ▶ DO wear a safety helmet to minimize the risk of head injury.
- ▶ DO ensure that the excavator operator is aware of your intentions.
- ▶ DO ensure that the unsupported part of the trench is safely battered.
- ▶ Do NOT climb up or down the struts.
- ▶ Do NOT use any unsupported part of the trench for access.
- ▶ Do NOT move the shield when personnel are inside it.

Since our policy is one of continual improvement, components may vary in detail from the descriptions given in this publication.

While information in this Guide is correct at time of printing, product specifications and product availability are subject to change without further notice. Please visit our website for the most up to date information. Job site photos are strictly intended for general product illustration only and may not comply with all applicable safety standards or site requirements. Specification data has been taken from manufacturers' serialised specific tabulated data.

**1800 622 394**

**[www.mabey.com/au](http://www.mabey.com/au)**

